

Features

- Compatible with 200lb (120l), 400lb (200L) and 600lb (400L) dump buggies.
- The tipping height is adjustable.
- Tip height 'without' a chute fitted:
Tip height adjustable range for 400lb bins is – 55 to 90" (in 4" increments)
Tip height adjustable range for 600lb bins is – 47 to 82.7" (in 4" increments)
- Tip height with a chute fitted:
Tip height adjustable range for 400lb bins is – 47 – 82.7" (in 4" increments)
Tip height adjustable range for 600lb bins is – 47 to 82.7" (in 4" increments)
- The machine is mobile as standard, with fixing brackets provided to fix the column dumper into position if required.
- 304 stainless steel
- Welded construction throughout
- Motor gearbox driven
- Chute fitted as standard

Technical Specifications

- Controls/orientation – Hold to run push buttons / Right-hand side
- Stainless steel – Grade 304
- Lifting capacity – 660 lbs
- Max tipping height (adjustable) – See description above
- Tipping reach – Customized to your application with a chute if required
- Tipping angle – 135 degrees (45 degrees from horizontal)
- Overall machine height – 127.5"
- Container suitability – Dump buggy 200, 400 + 600lb (or similar container)
- Base – Mobile base (with fixing brackets on base frame)
- Mains supply as std – 480v 3PH 60Hz – Grounded (can be switched to 240v on site)
- Control circuit – 24V AC
- Electrical rating – IP65
- Drive Type – Braked motor gearbox + roller chain (simplex 3/4" chain)
- Lift speed – 21 ft/min
- Approx net machine weight – 660 Lb

Customized options available

- Guarding and Fixed base
- We have 'off the shelf' machines, that can be further customized, or we can create a new solution for your specific needs.



1 2 3 4 5 6

A

B

C

D

E

F

G

H

A

B

C

D

E

F

G

H

ISCA
Stainless Steel Fabrication



PROPRIETARY AND CONFIDENTIAL

The information contained in this drawing is the sole property of ISCA.
Any reproduction, in part or as a whole, without the written permission of ISCA is prohibited.

Unless otherwise specified:
Dimensions are in inches [mm]
Surface finish:
Tolerances: imperial [metric(±15)]
Linear: x.xx 0.2 (xxx 0.01)
Angular: xx' 010

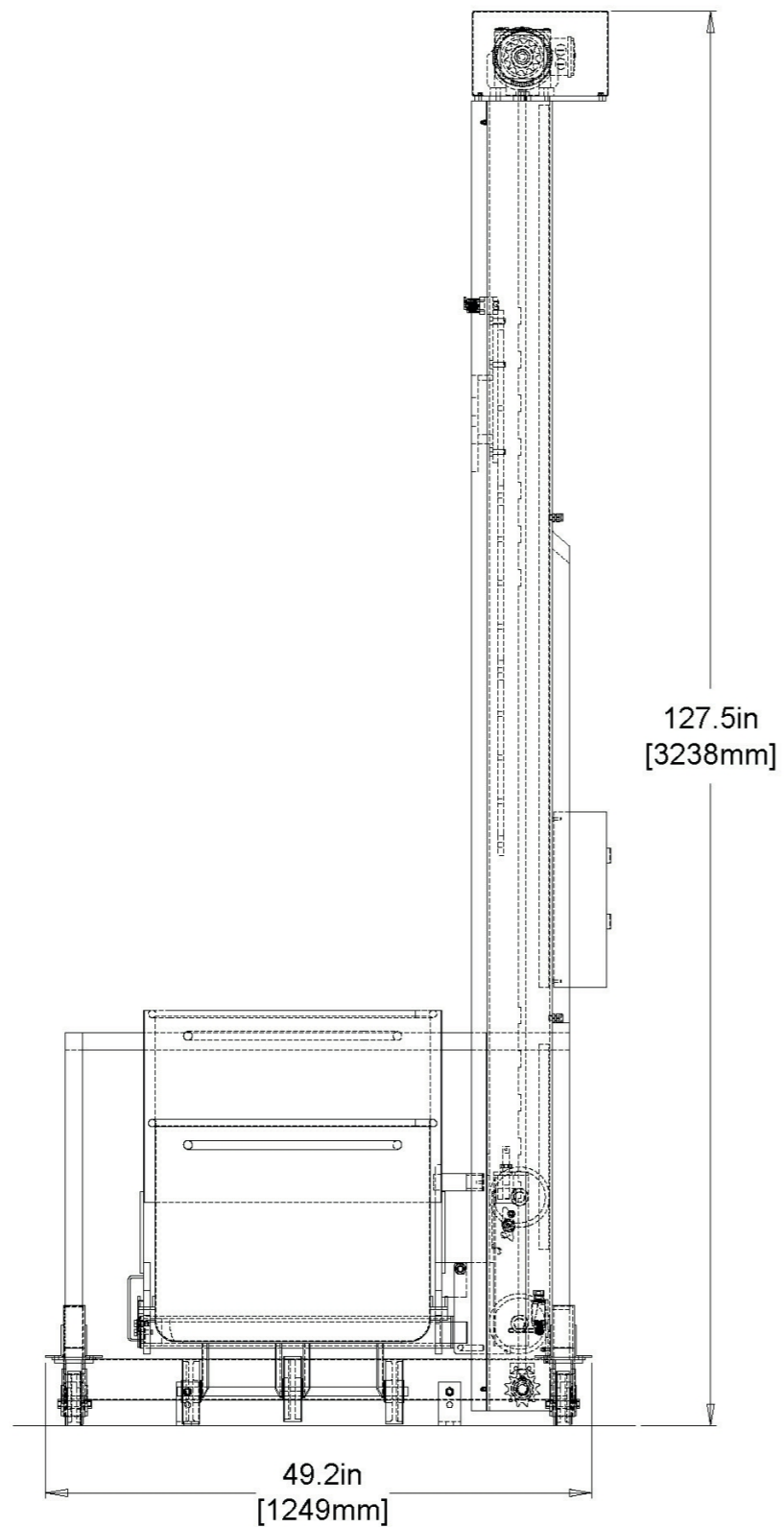
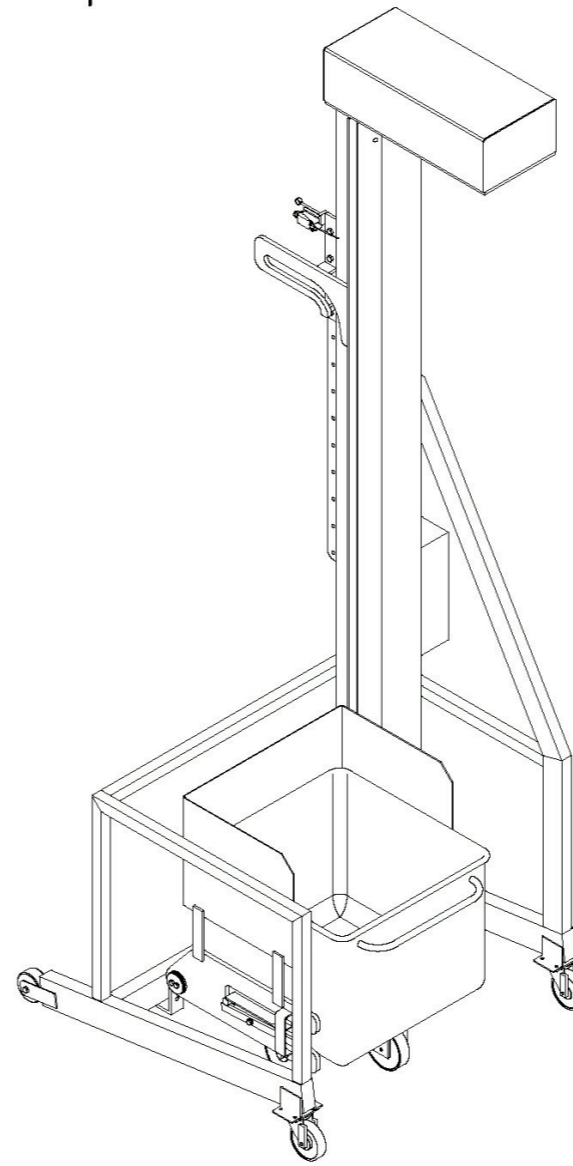

CONTROL PANEL

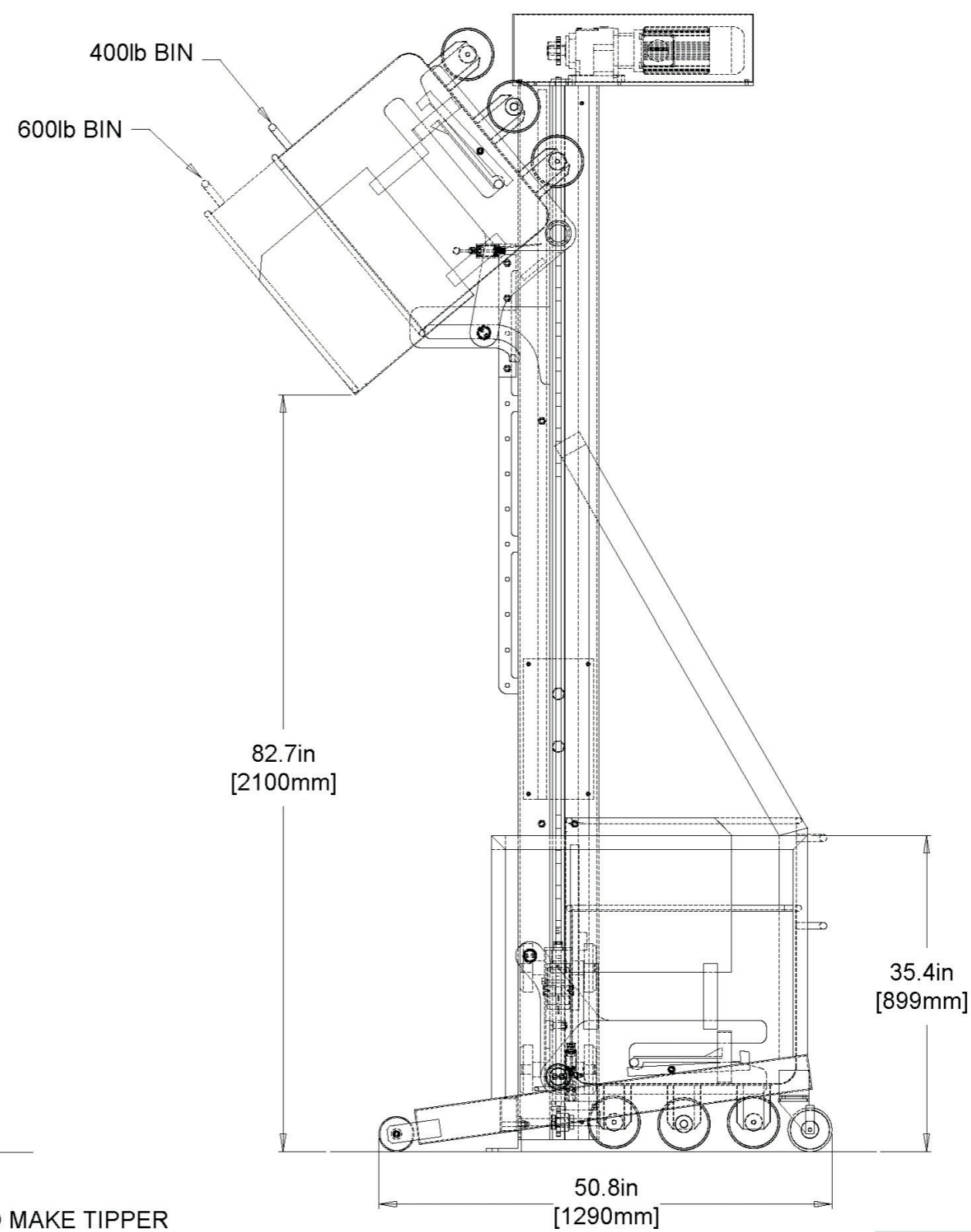
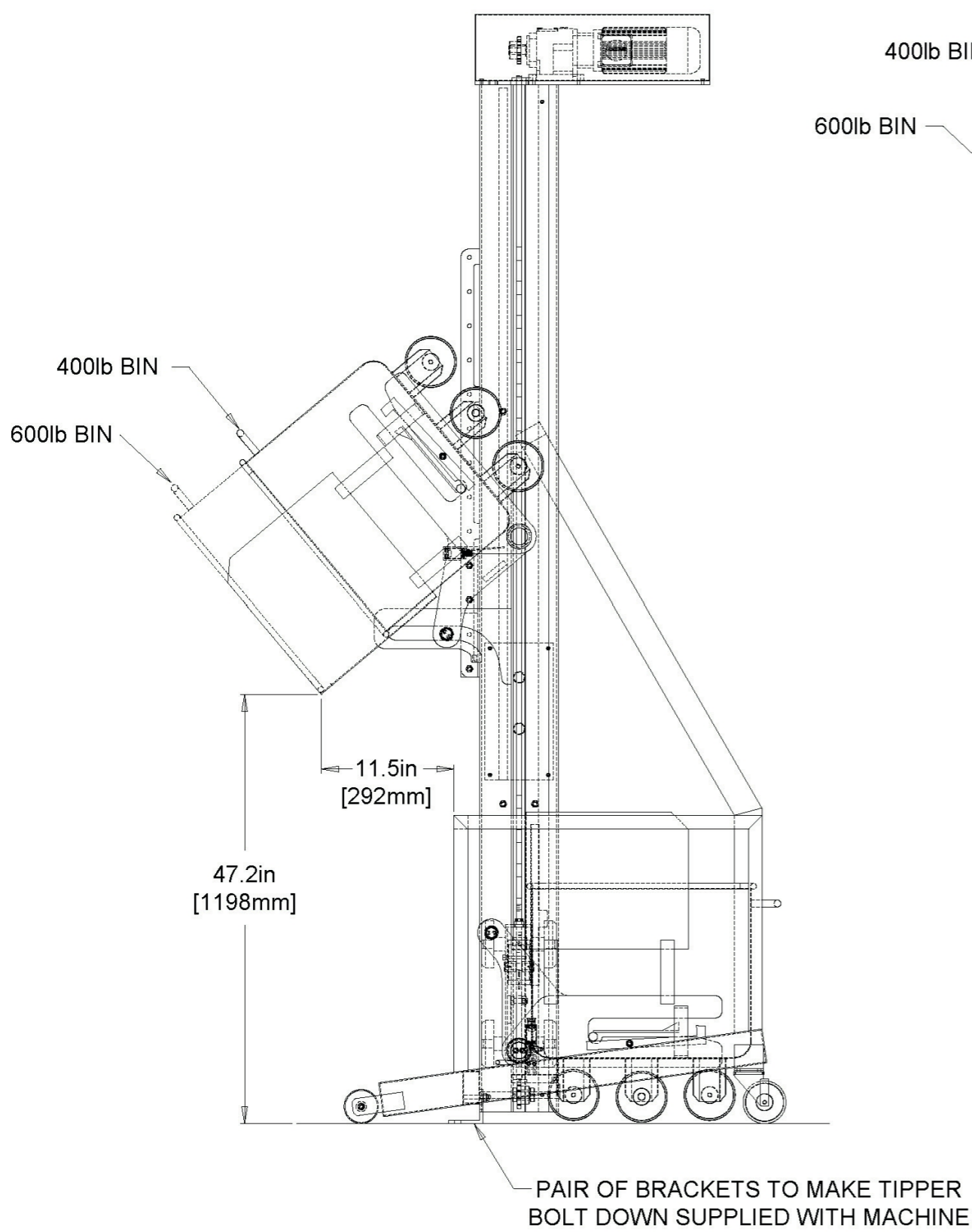
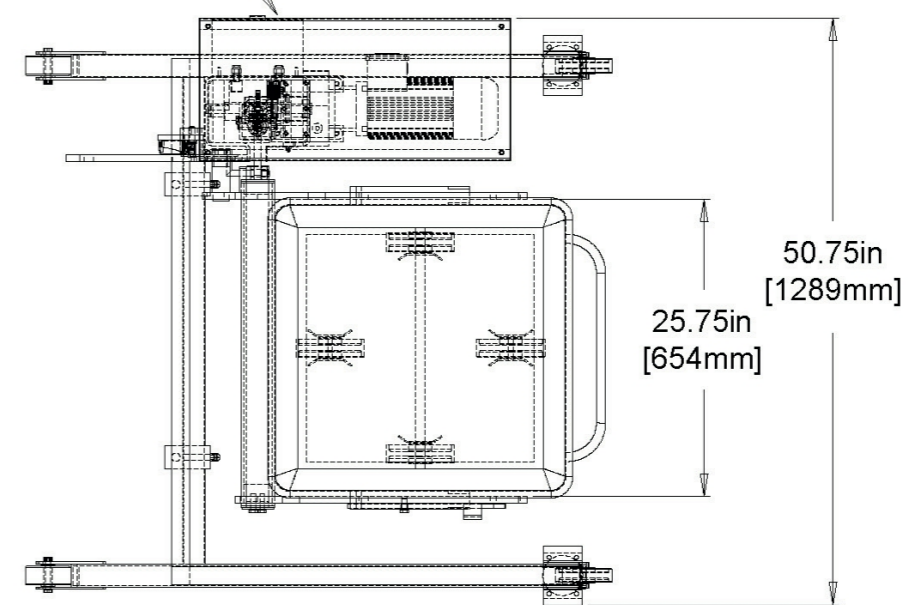

product no:

ISCA - Column Dumper

1 2 3 4 5 6

Wash



Store



Protect & Identify



ISCA Dump Buggy Solutions

Weigh



Transfer



Lift + Tip



Mix



Transport

