

Features

An automatic boot washer for hygienic entrance corridors entering into production areas. For cleaning the sole and calf of footwear.

The machine commands a small footprint and is floor-mounted as standard.

The brush is activated by a stainless steel button on the handle, which simultaneously releases the cleaning agent and water mixture.

Features:

- Stainless steel Grade 304
- Welded body
- Adjustable leg height
- Hard wearing, anti deformation brushes
- Handheld button start/stop function
- with 10 liter plastic container for disinfectant liquid.

Technical Specifications

- Dimensions: 865 x 809 x 1100 mm
- Electrical power supply 480 V ,3 Ph ,50/60Hz
- Water supply 3/4"
- Brush length 13.7" / 350mm

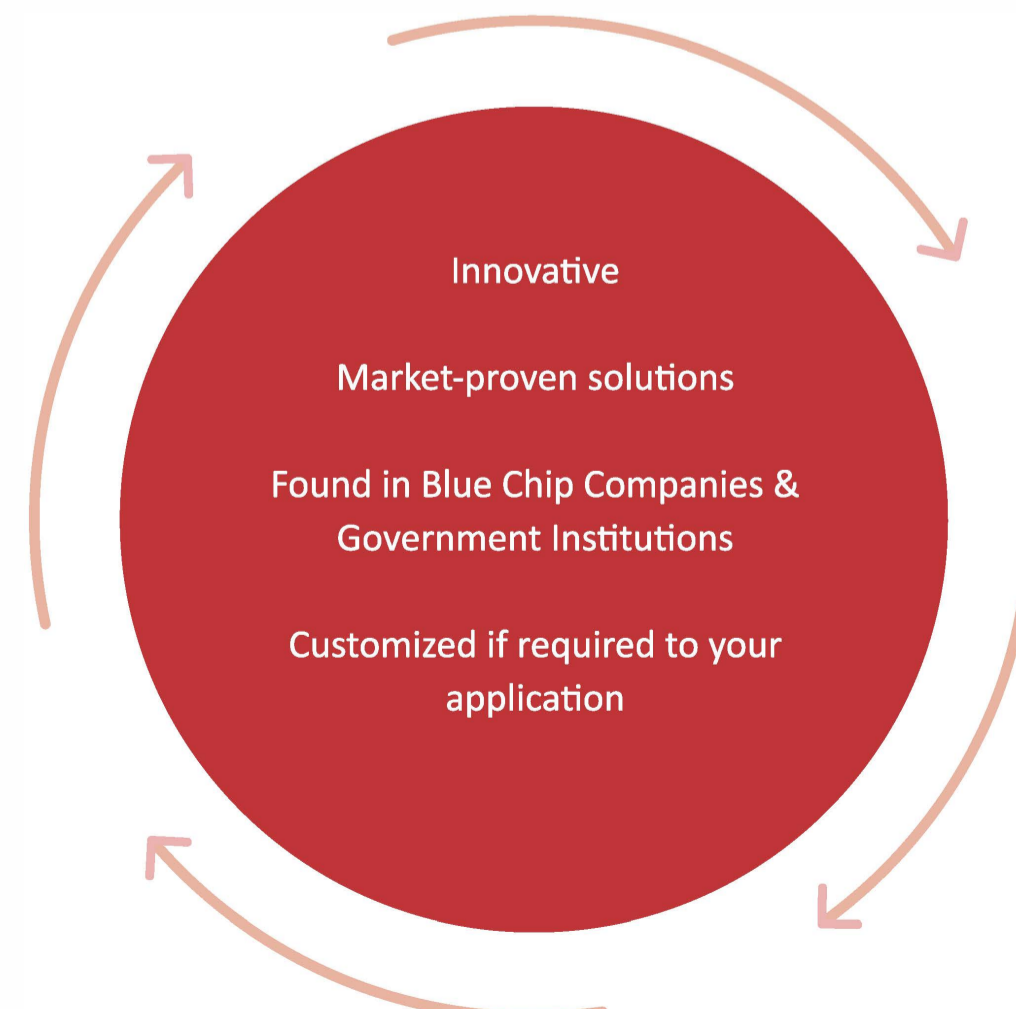
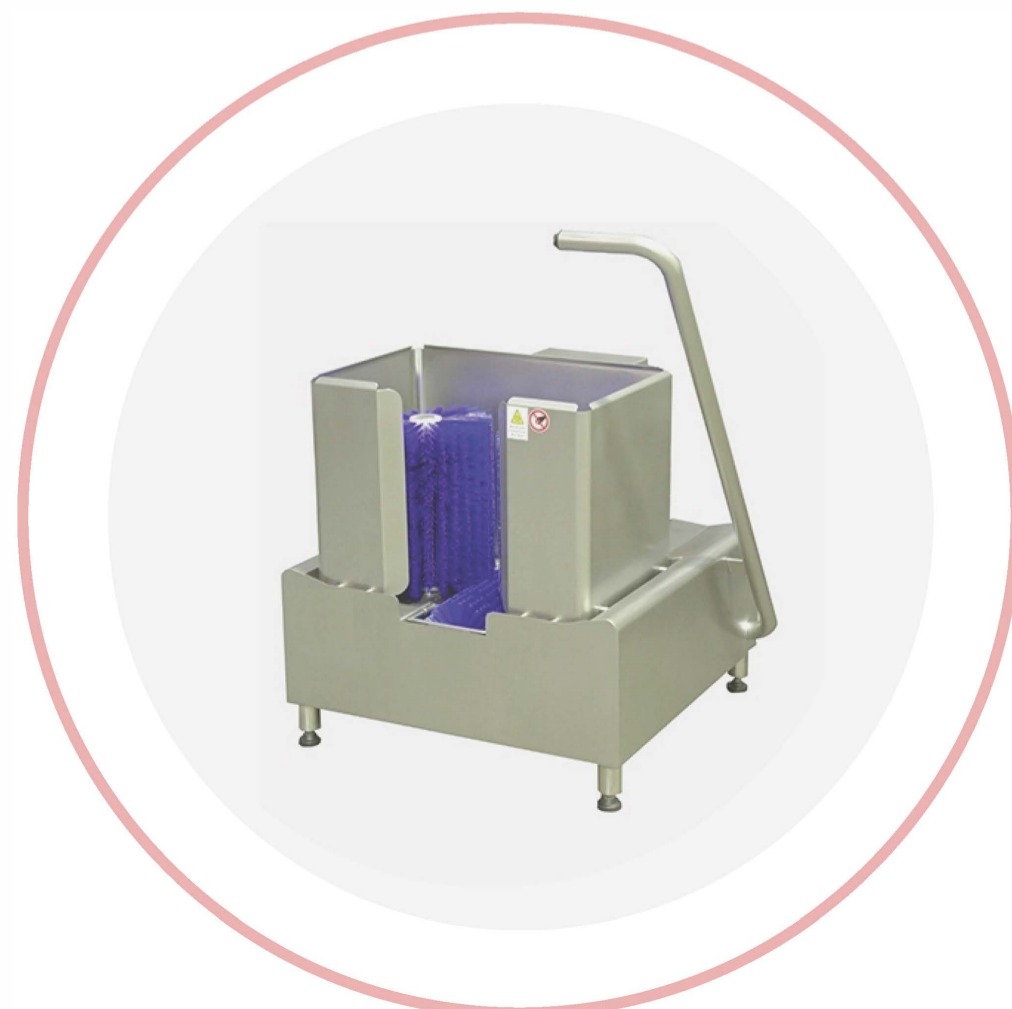

1

2

3

4

5

6

7

8

A

B

C

D

E

F

A

B

C

D

E

F

32in [814mm]

34in [864mm]

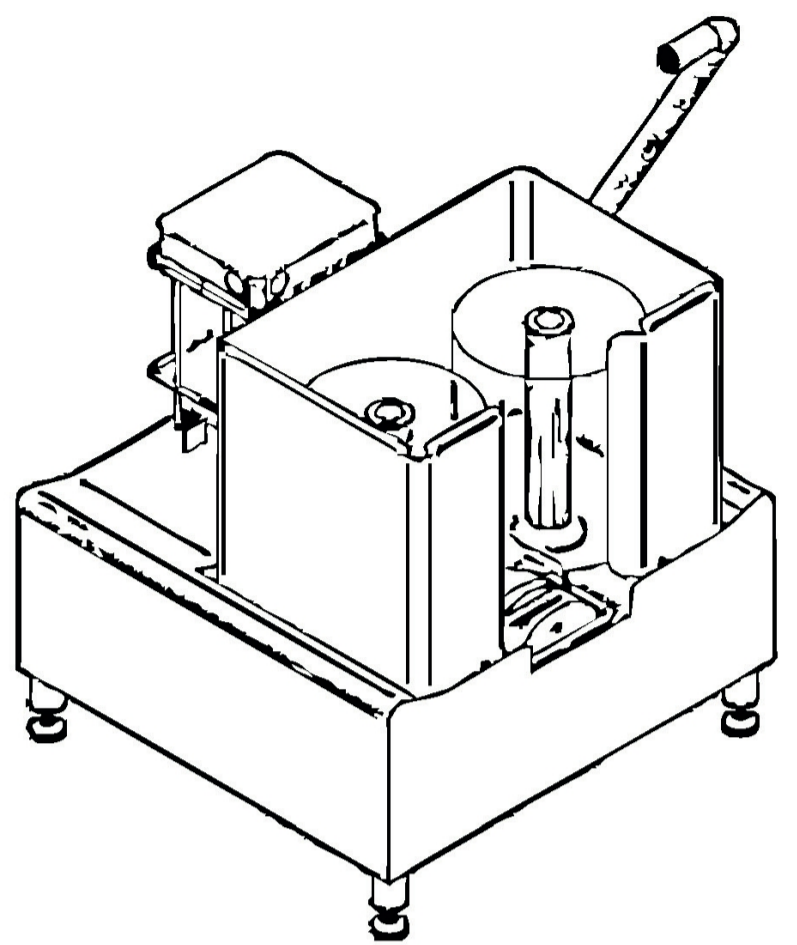
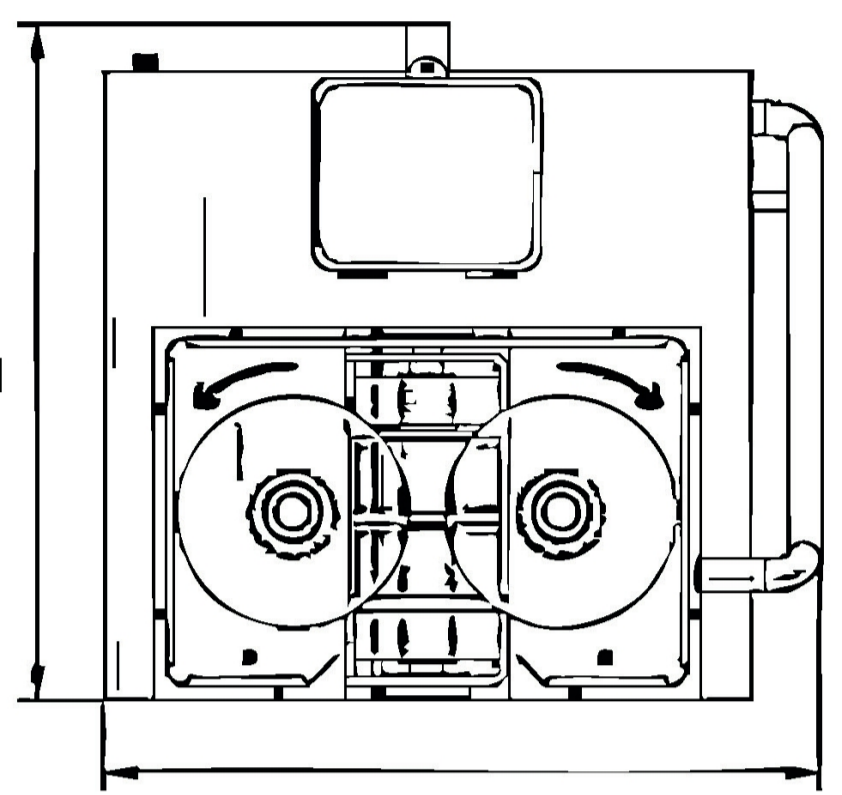

ISCA
Stainless Steel Fabrication



PROPRIETARY AND CONFIDENTIAL
The information contained in this drawing is the sole property of ISCA
Any reproduction, in part or as a whole, without the written permission of ISCA is prohibited.

Unless otherwise specified:
Dimensions are in inches [mm]
Surface finish:
Tolerances: imperial [metric(±15)]
Linear: x.xx 0.2 (.xxx 0.01)
Angular: xx' 010

13.4in [342mm]

45.1in [1147mm]

32.1in [817mm]

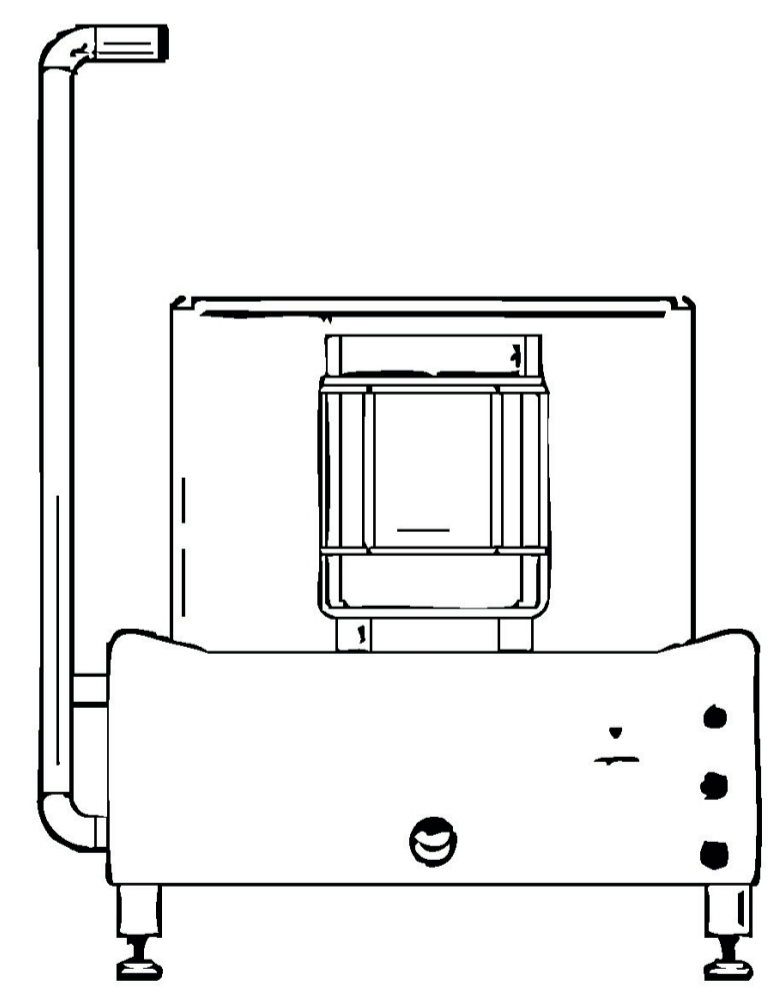
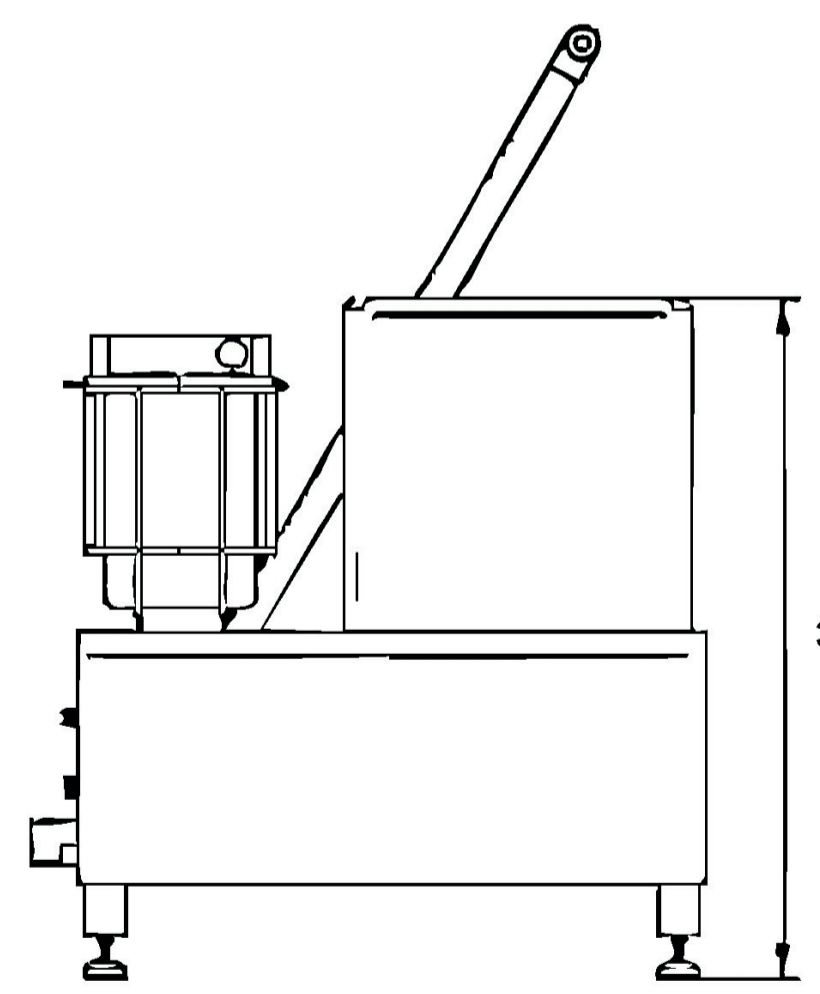
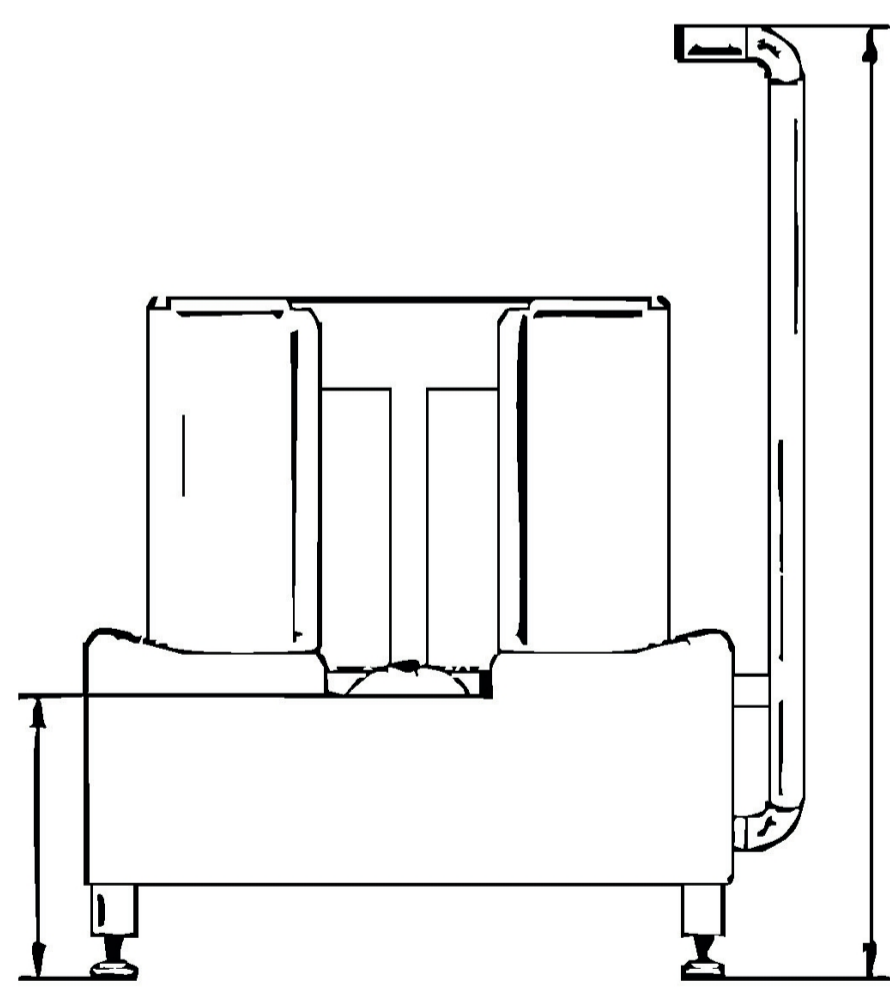

product no:
ISCA - 11 - High boot and sole washer

1

2

3

4

5

6

7

8

Footwear storage

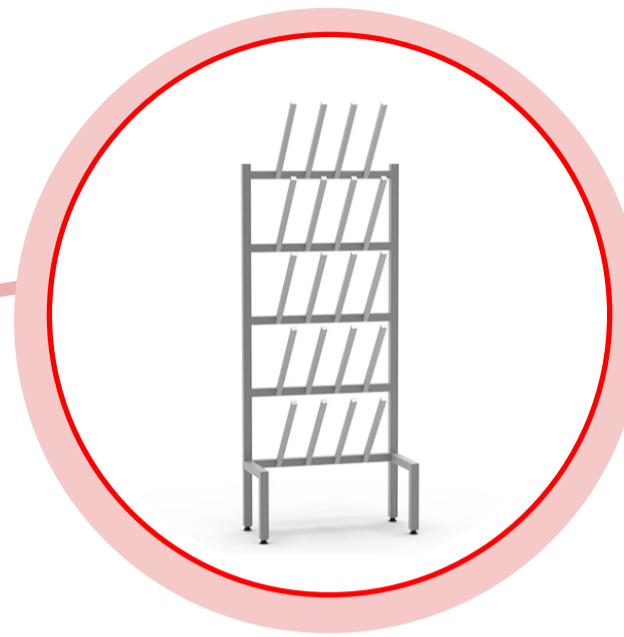

Workwear storage



**ISCA's
Hygiene
Equipment
Solutions**

Hygiene entrance stations

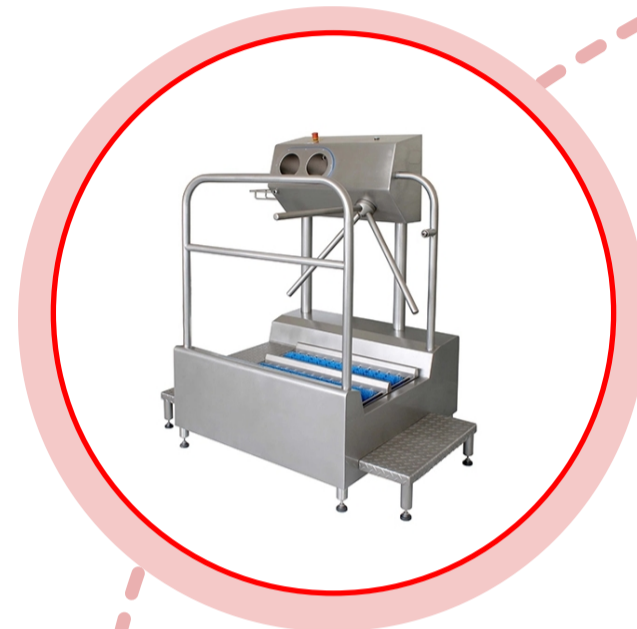

Manual bootwashers



Hand washing



Automatic boot washers