

Features

An automatic integrated hygiene entrance station.

Features:

- Footwear washer
 - Washbasin with sensor switch
 - Soap dispenser
 - Disinfection liquid dispenser
 - Paper towel dispenser
 - Paper bin
 - Shelf for detergents
-
- Stainless steel Grade 304
 - Welded body

Technical Specifications

- Dimensions: 790 x 500 x 1600 mm
- Water supply:
washbasin (cold/ hot water): 1/2", footwear washer: 3/4"
- Wastewater outflow: DN 32
- Power supply: 230V AC, 60 Hz, installed
- Power 0,18 kW

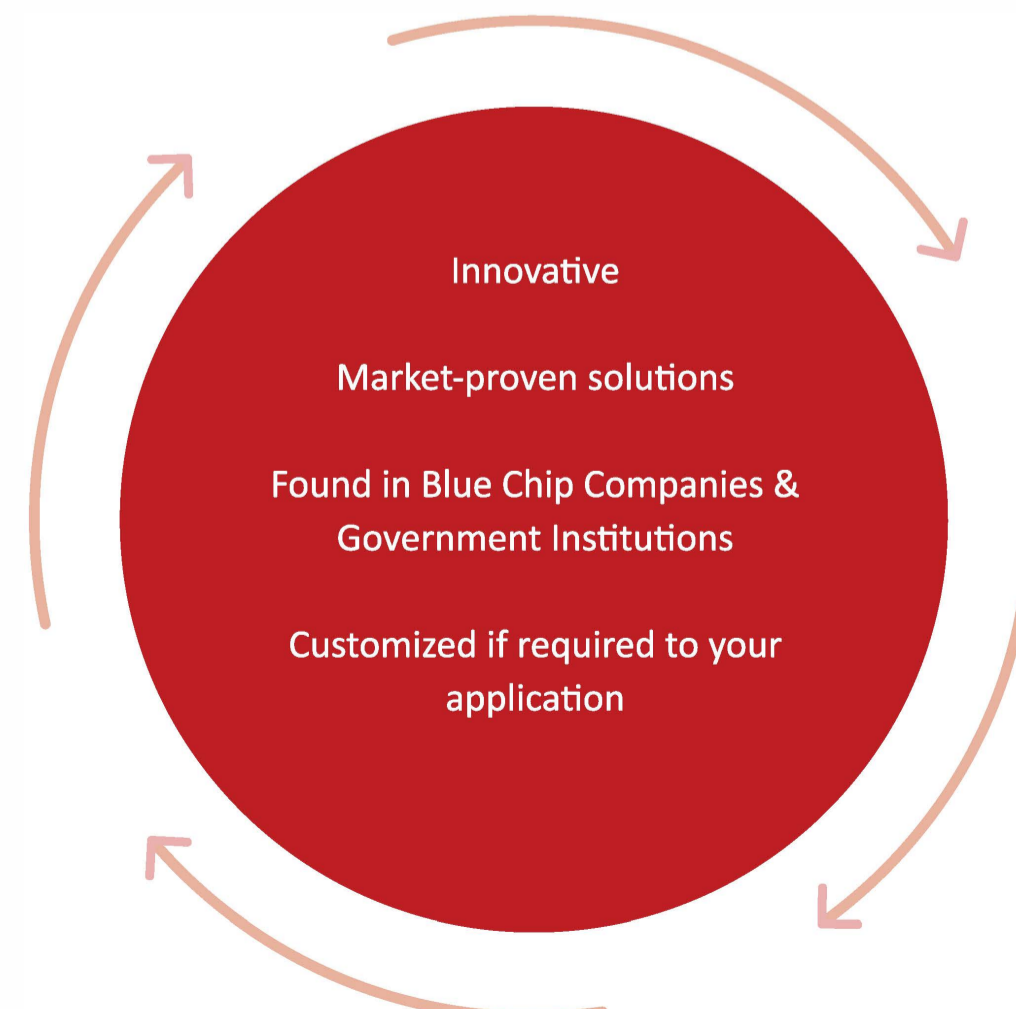

1 2 3 4 5 6 7 8

A

B

C

D

E

F

A

B

C

D

E

F

ISCA
Stainless Steel Fabrication



PROPRIETARY AND CONFIDENTIAL
The information contained in this drawing is the sole property of ISCA
Any reproduction, in part or as a whole, without the written permission of ISCA is prohibited.

Unless otherwise specified:
Dimensions are in inches [mm]
Surface finish:
Tolerances: imperial [metric(±15)]
Linear: x.xx 0.2 (.xxx 0.01)
Angular: xx' 010

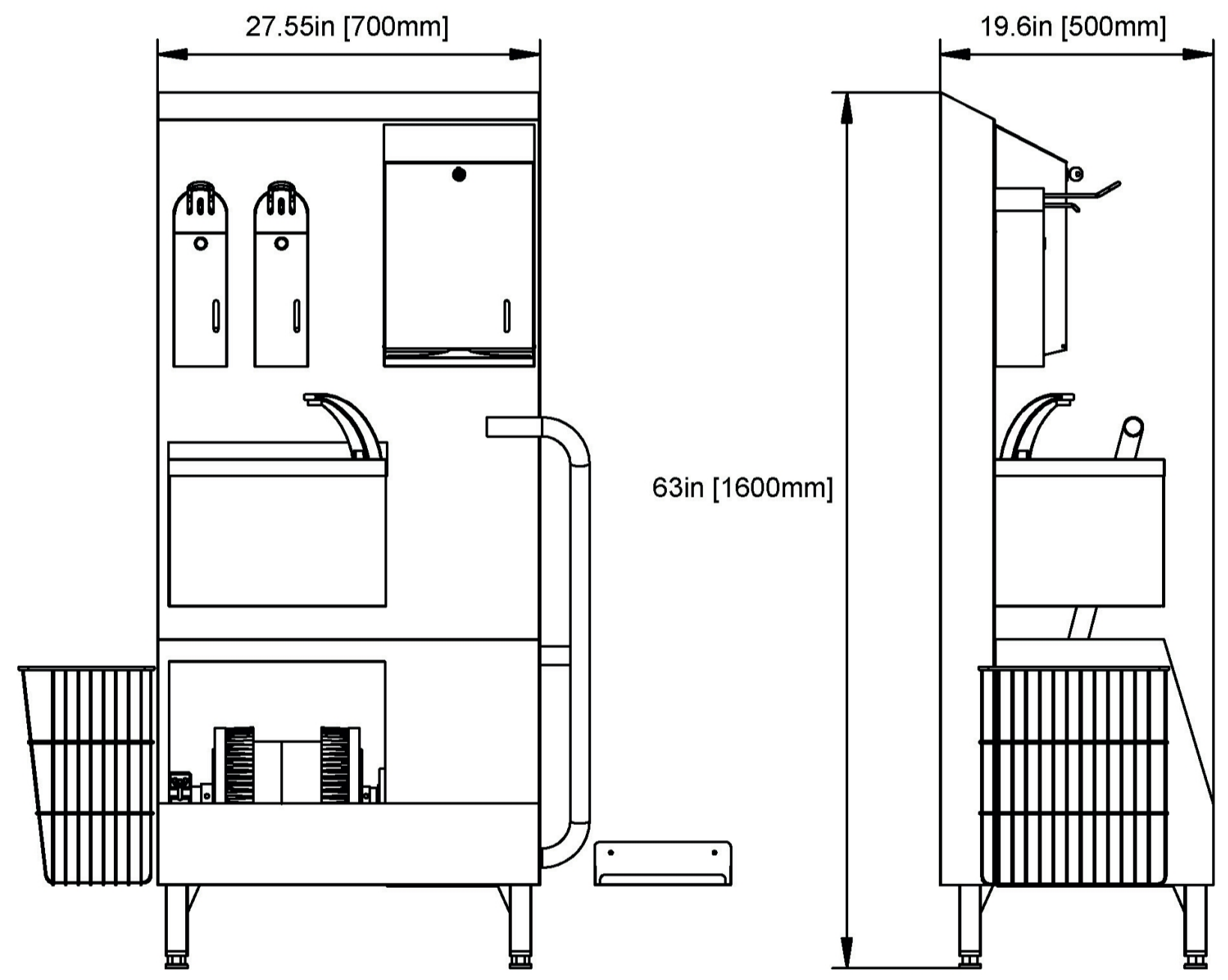

WALL MOUNTING STRIP

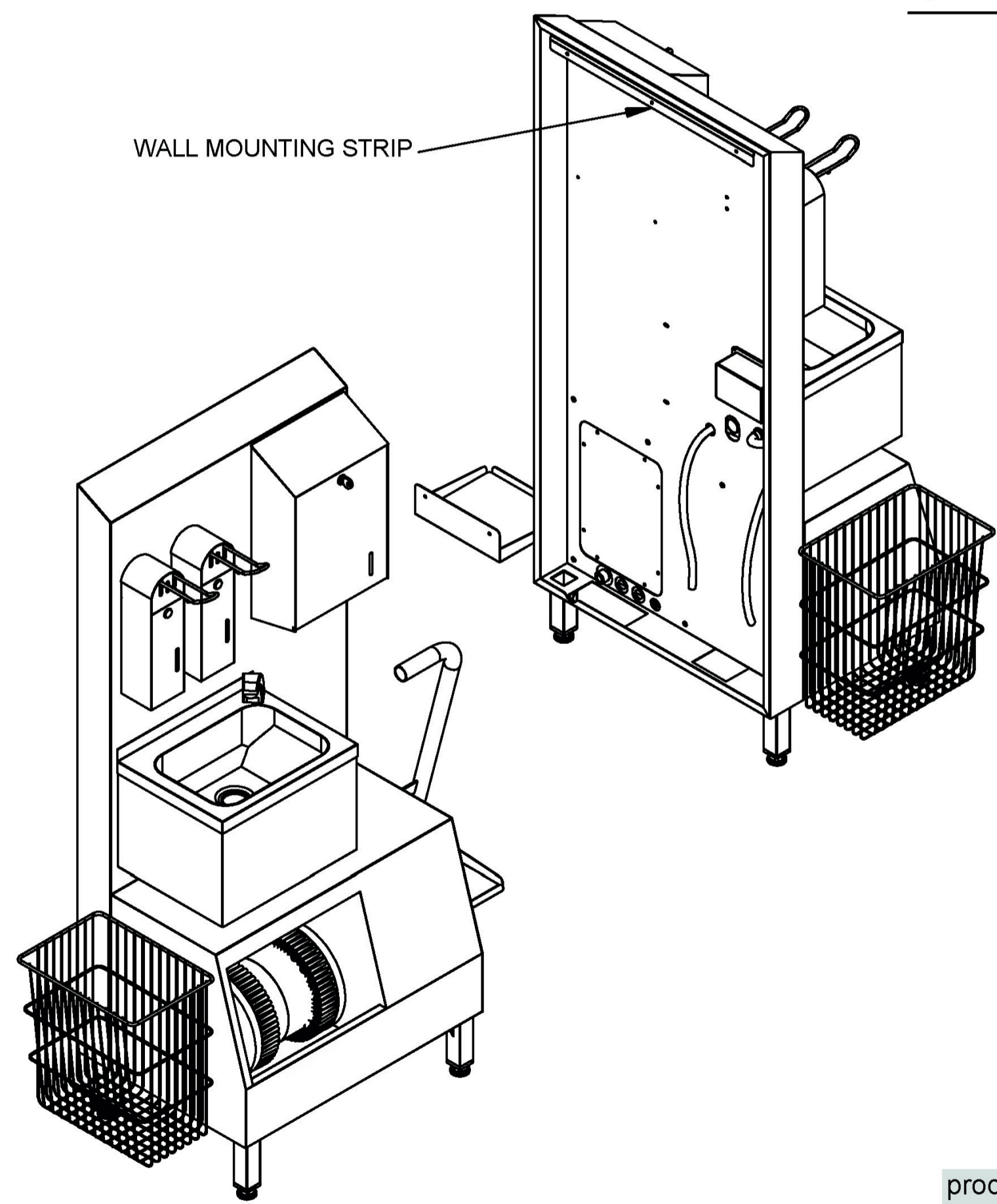

product no:
ISCA - Automatic Hygiene Entrance Station

1 2 3 4 5 6 7 8

Footwear storage

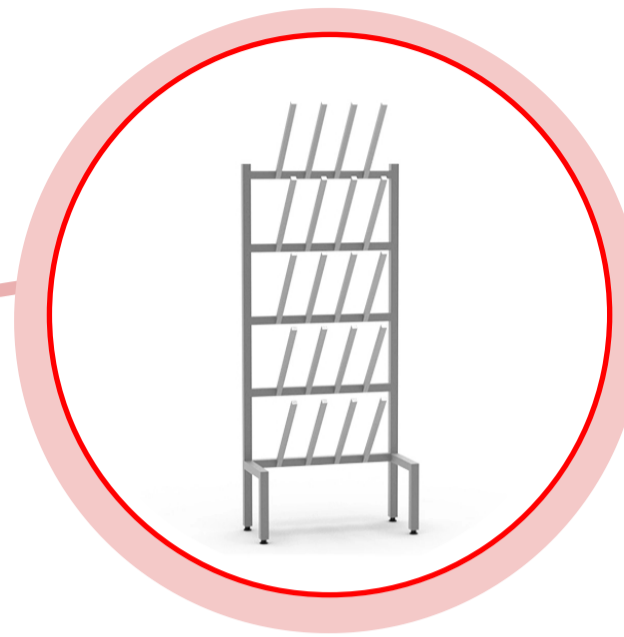

Workwear storage



**ISCA's
Hygiene
Equipment
Solutions**

Hygiene entrance stations



Manual bootwashers



Hand washing

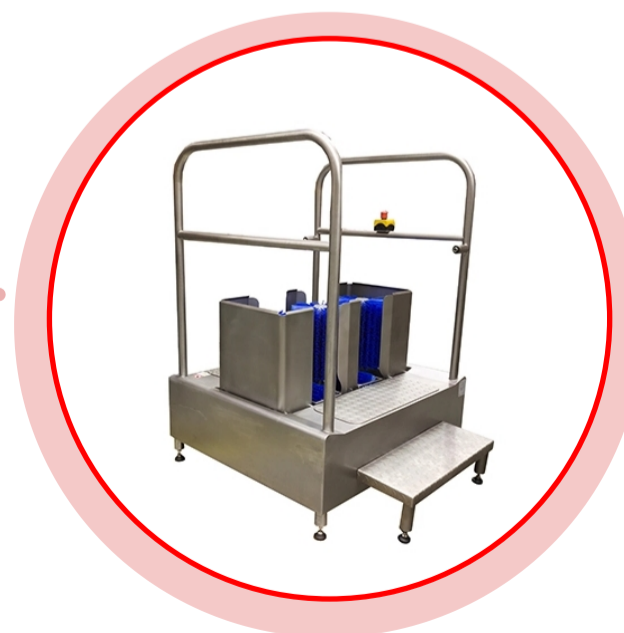

Automatic boot washers