

Features

Integrated Automatic Walk through Hygiene Entrance Station – with hand drier

Features:

- Hand washing chamber, hand dryer, hand disinfecting chamber and shoe soles' washer
- Stainless steel Grade 304
- Welded body
- Adjustable leg height

Technical Specifications

- Power supply 480V, 60 Hz
- Control vol-tage 24V DC
- Power 0,6 kW
- PLC controller
- 3.8" TFT touch panel
- Water supply 3/4"
- Waste outflow diameter 50mm

Customized options available

- Turnstile on left or right
- Rotate in one or two directions

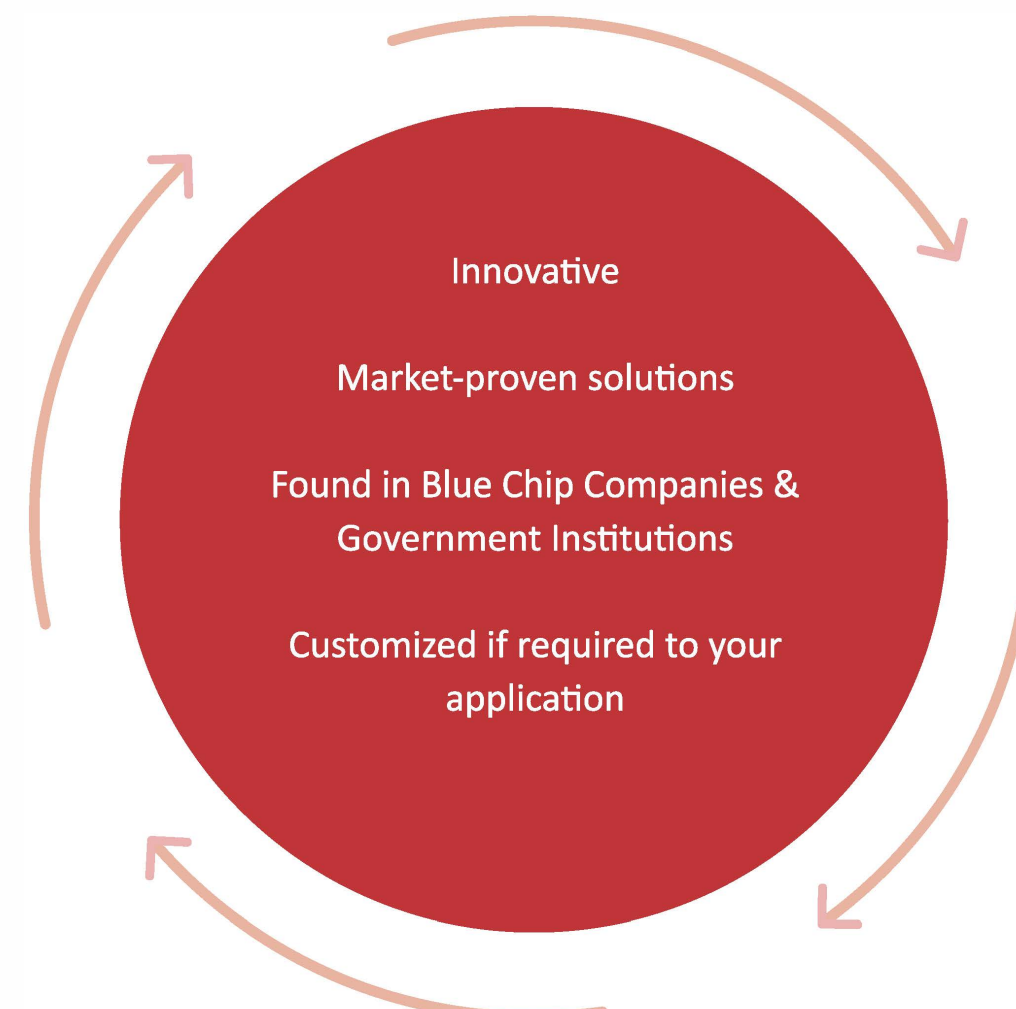

1 2 3 4 5 6 7 8

A
B
C
D
E
F

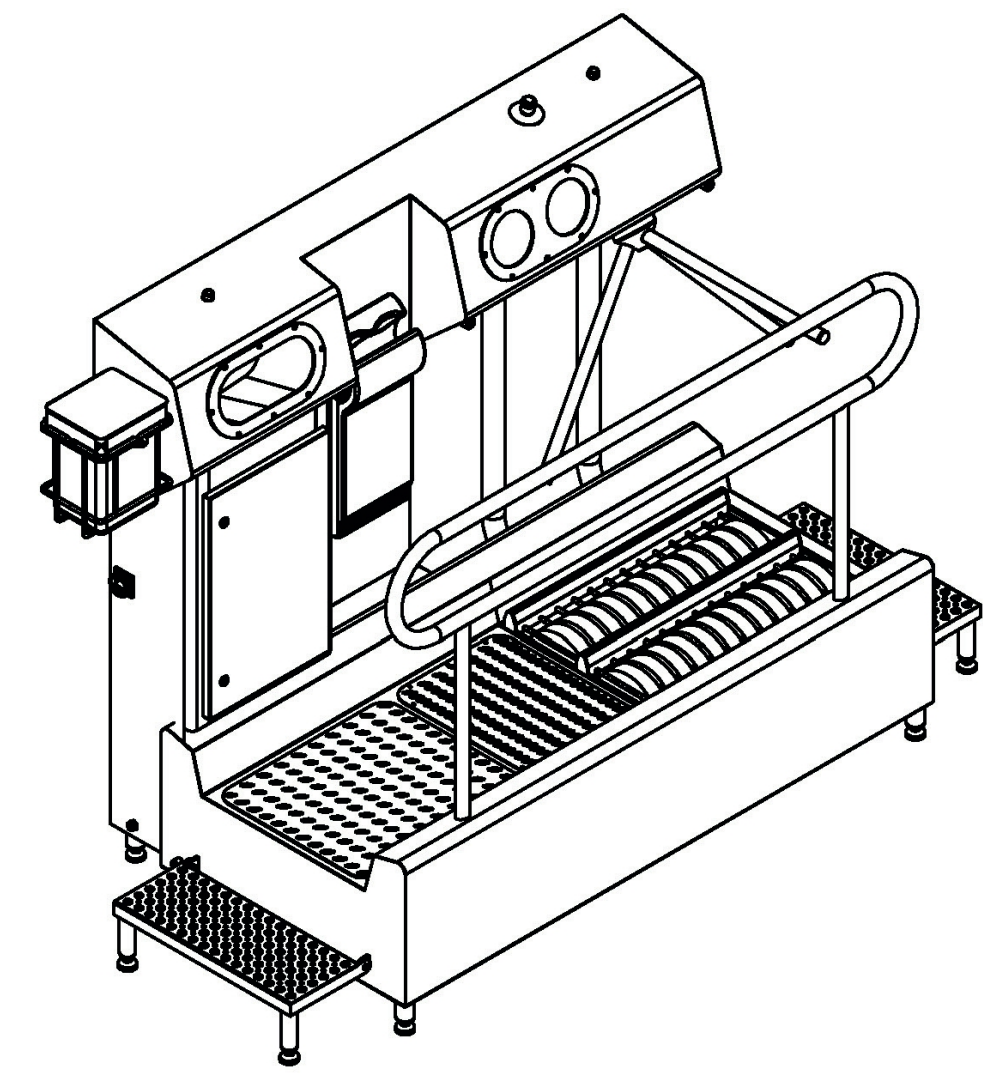
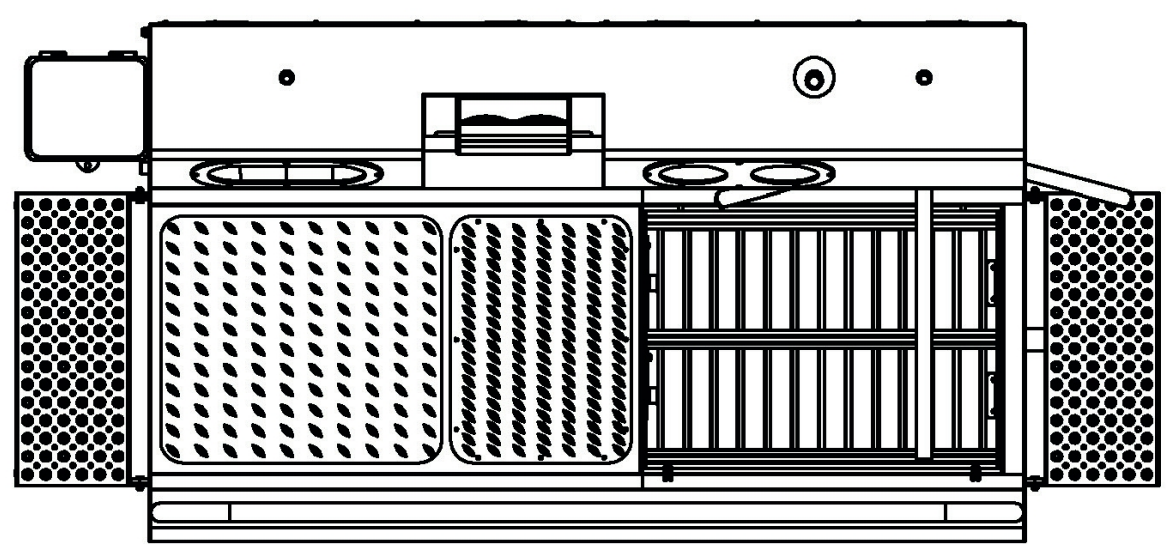
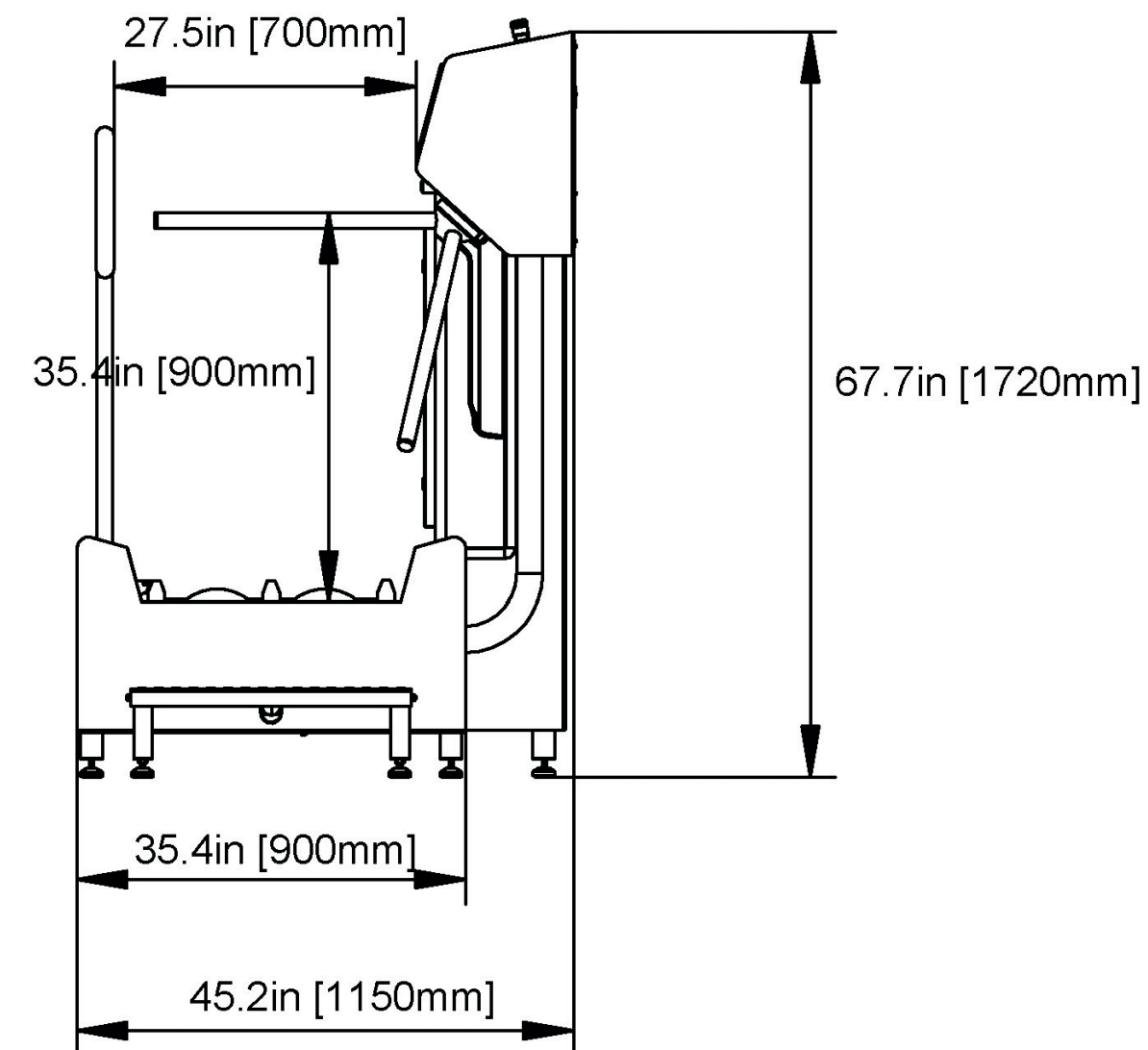
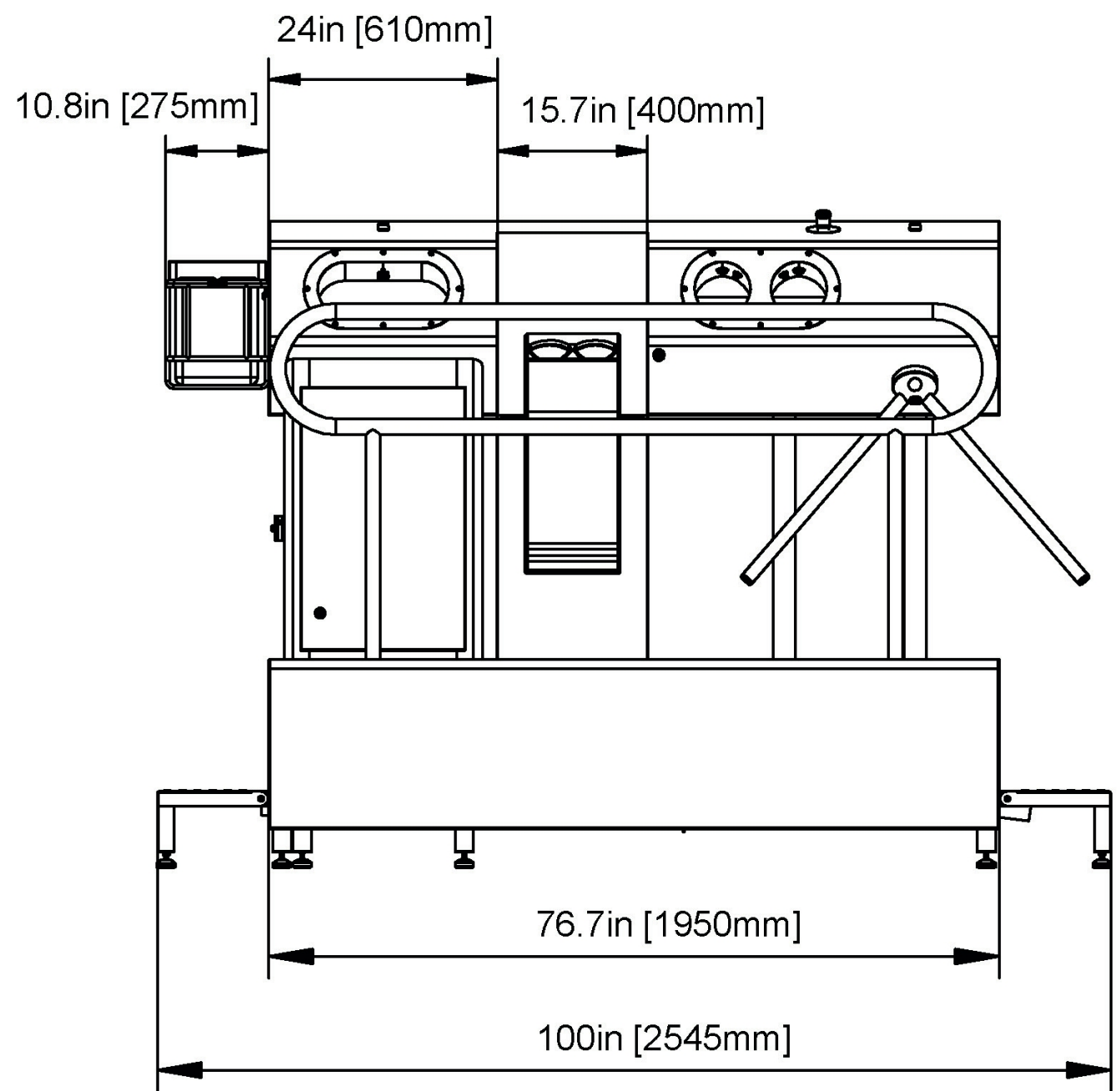

PROPRIETARY AND CONFIDENTIAL
 The information contained in this drawing is the sole property of ISCA
 Any reproduction, in part or as a whole, without the written permission of ISCA is prohibited.

Unless otherwise specified:
 Dimensions are in inches [mm]
 Surface finish:
 Tolerances: imperial [metric(±15)]
 Linear: x.xx 0.2 (.xxx 0.01)
 Angular: xx' 010

product no:
**ISCA - Automatic
 Walkthrough Hygiene
 Entrance Station**

1 2 3 4 5 6 7 8

Footwear storage

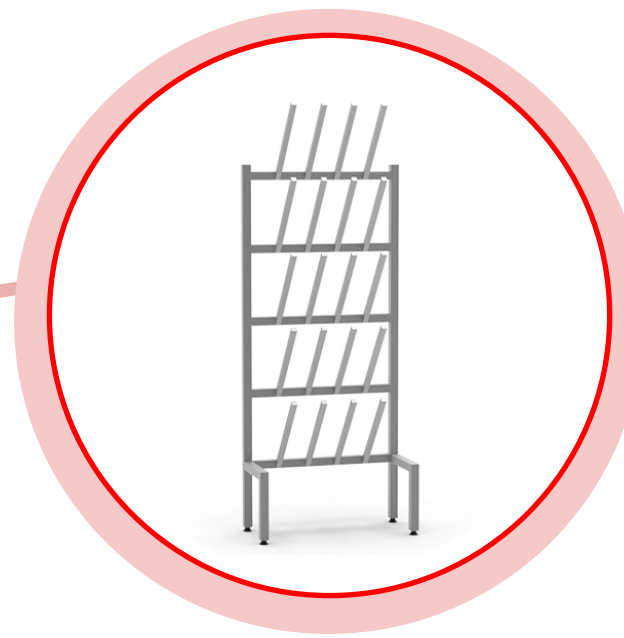

Workwear storage



**ISCA's
Hygiene
Equipment
Solutions**

Hygiene entrance stations



Manual bootwashers



Hand washing

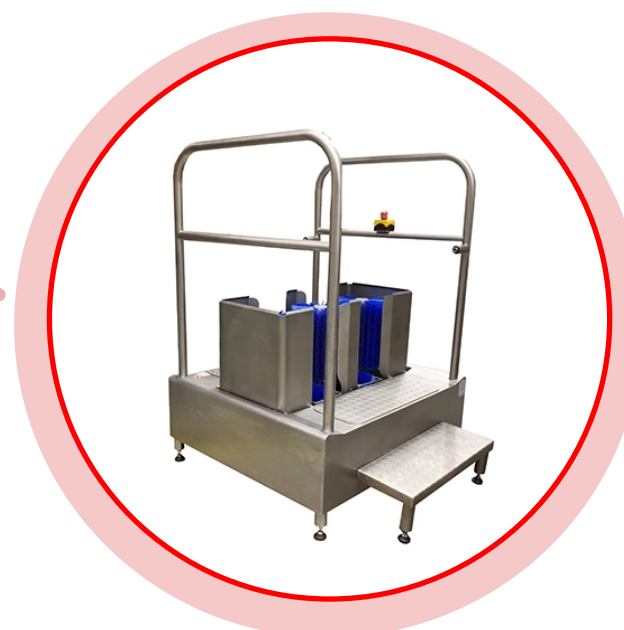

Automatic boot washers