

## Features

- Compatible with removable bakery bowls
- The tipping height is 63" (1600mm)
- Safe working load of 330Lb (150Kgs)
- The machine is mobile as standard, with fixing brackets provided to fix the column dumper into position if required.
- 304 stainless steel
- Welded construction throughout
- Motor gearbox chain-driven system

## Technical Specifications

- Controls/orientation – Hold to run push buttons / Right-hand side
- Stainless steel – Grade 304
- Lifting capacity – 320 lb (150 kg)
- Tipping height – 63" (1600 mm)
- Tipping reach – Customized to your application with a chute if required
- Tipping angle – 130 degrees (40 degrees from horizontal)
- Overall machine height – 94.4" (2397 mm)
- Container suitability – Hobart mixing bowl (or similar container)
- Base – Mobile base (with fixing brackets on base frame)
- Mains supply as std – 480v 3PH 60Hz – Grounded (can be switched to 240v on site)
- Control circuit – 24V AC
- Electrical rating – IP65
- Drive Type – Braked motor gearbox + roller chain (simplex 3/4" chain)
- Lift speed – 21 ft/min

## Customized options available

- Guarded machine and Fixed base machine
- We have 'off the shelf' machines, that can be further customized, or we can create a new solution for your specific needs.

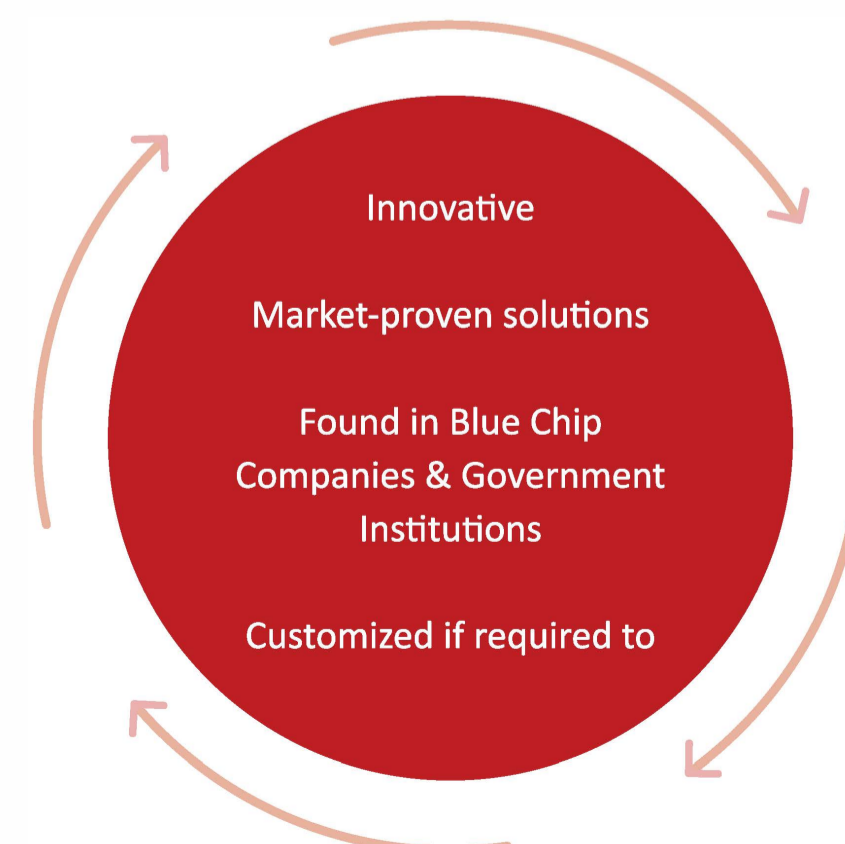

1 2 3 4 5 6

A

B

C

D

E

F

G

H

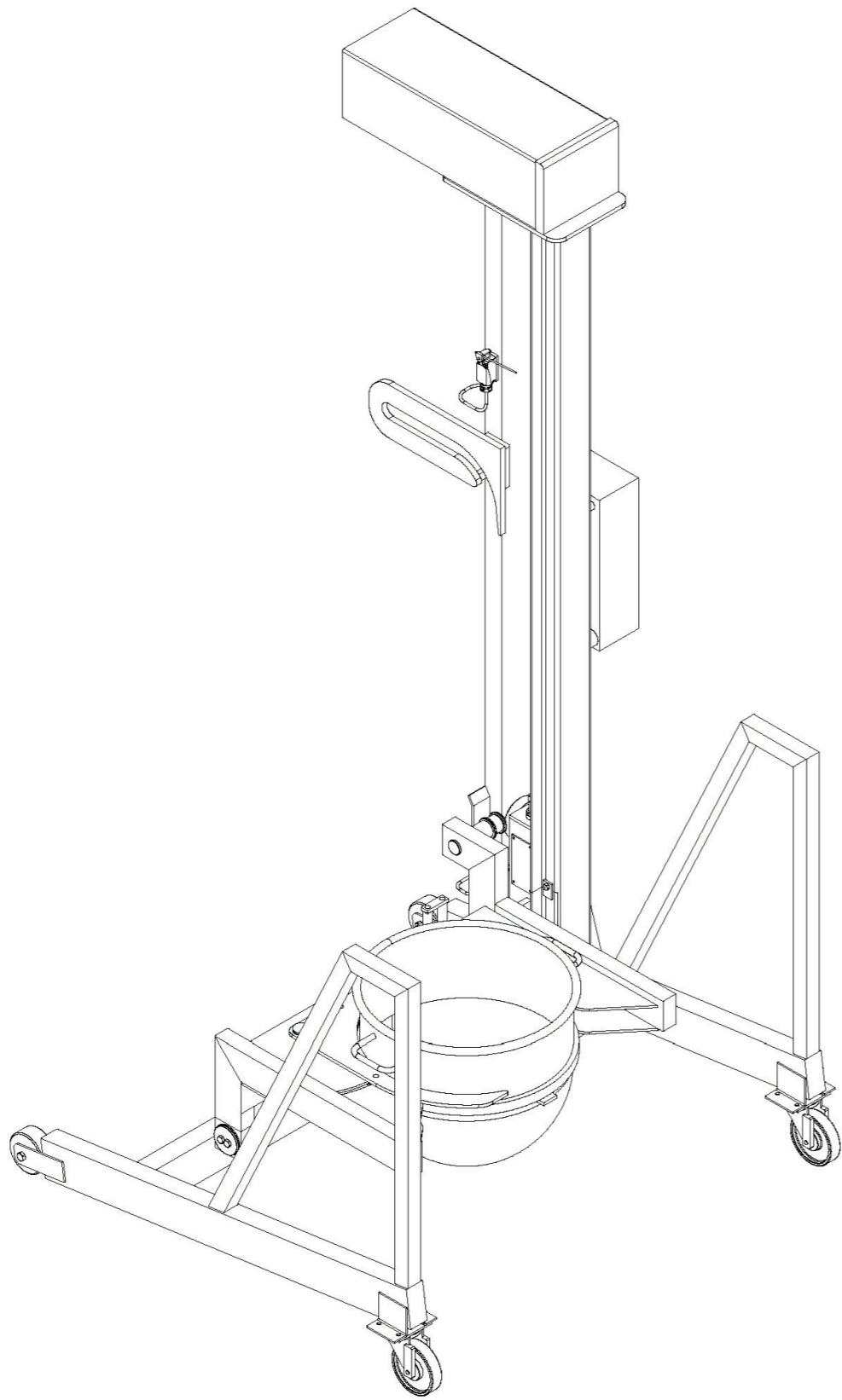

ISCA  
Stainless Steel Fabrication



**PROPRIETARY AND CONFIDENTIAL**  
 The information contained in this drawing is the sole property of ISCA.  
 Any reproduction, in part or as a whole, without the written permission of ISCA is prohibited.

Unless otherwise specified:  
 Dimensions are in inches [mm]  
 Surface finish:  
 Tolerances: imperial [metric(±15)]  
 Linear: x.xx 0.2 (.xxx 0.01)  
 Angular: xx' 010

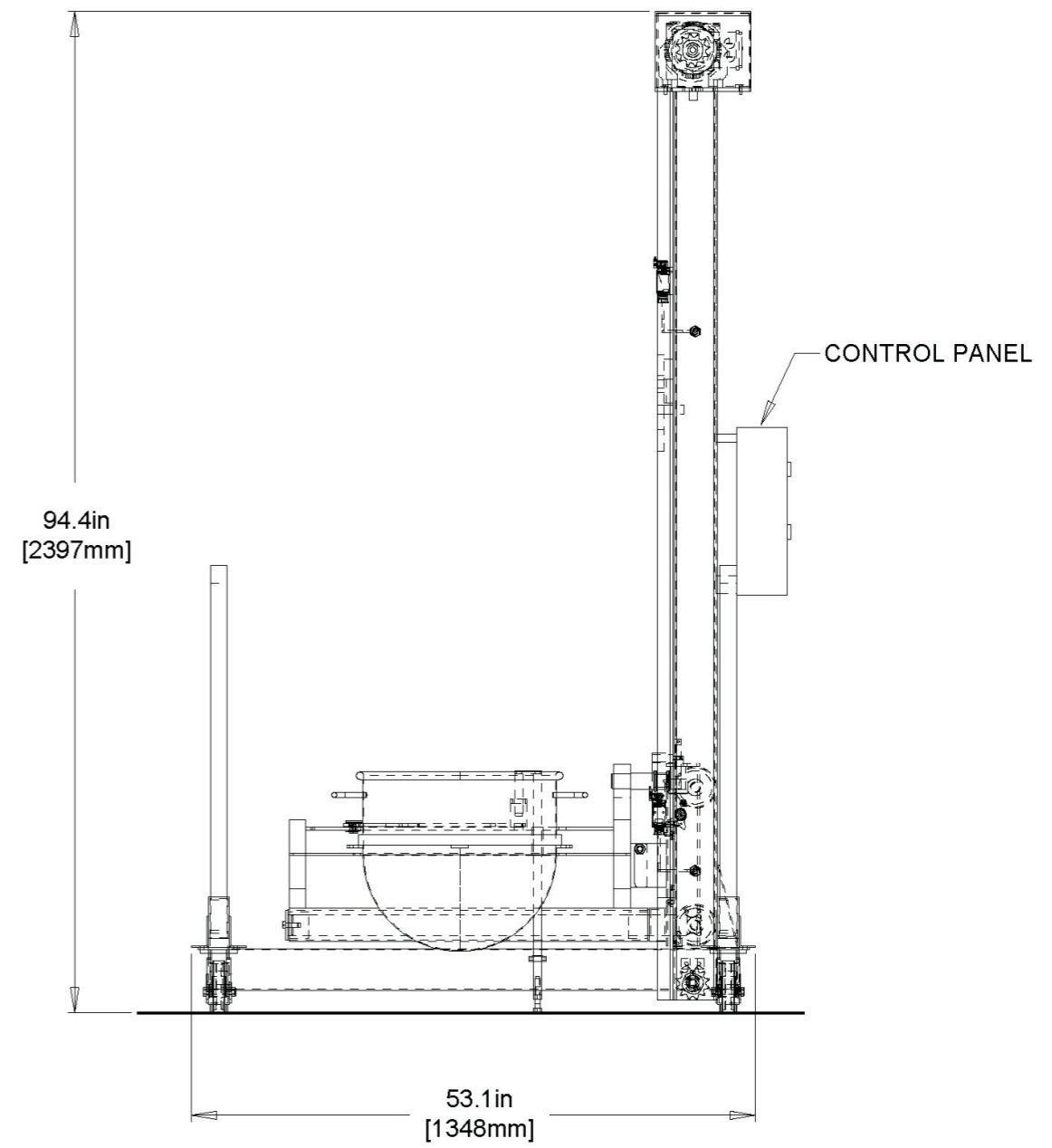
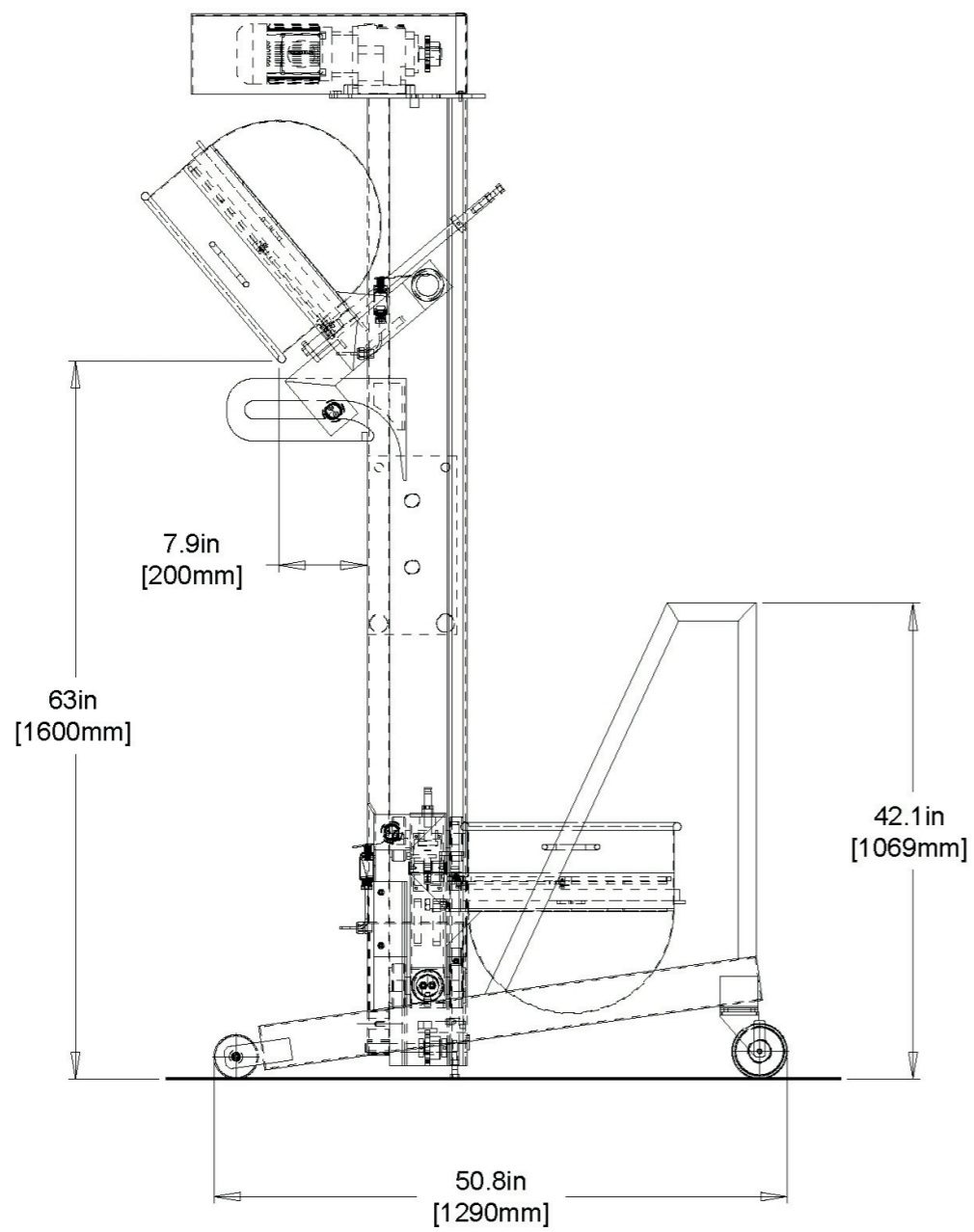
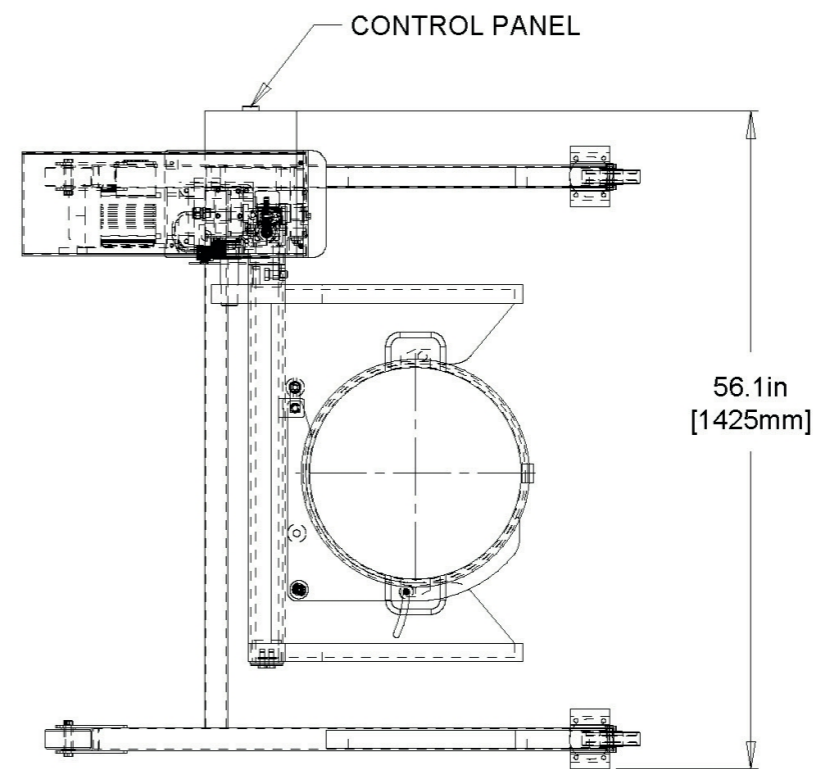

product no:  
**ISCA- Hobart Bowl Tipper**

1 2 3 4 5 6

**High-level lift + tip**



**Store + Transport**



**ISCA's  
Bakery Bowl  
Solutions**

**Low-level lift + tip**



**Table Tip**

