

## Features

- Compatible with 200lb (120L), 400lb (200L), and 600lb (400L) dump buggies
- The tipping height is fixed at 39" (1000mm)
- Tipping angle = 30 degrees past the horizontal
- The machine is mobile as standard, on two fixed, and two swivel castor wheels
- 304 stainless steel
- Welded construction throughout
- Hydraulic power pack (Stainless steel hydraulic cylinder)
- The hydraulic cylinder is fitted with a safety check valve such that even in the unlikely event of a hydraulic hose failure, the raised bin will not fall to the floor
- Chute fitted to the lift carriage as standard

## Technical Specifications

- Controls/orientation – Hold to run push buttons / Right-hand side
- Stainless steel – AISI 304
- Lifting capacity – 660 lbs
- Max tipping height = 39" (1000mm)
- Tipping reach – Customized to your application with a chute if required
- Tipping angle = 30 degrees past the horizontal
- Container suitability – Dump buggy 200, 400 + 600lb (or similar container)
- Base – Mobile base
- Mains supply as std – 480v 3PH 60Hz – Grounded (can be switched to 240v on site)
- Control circuit – 24V AC
- Electrical rating – IP65
- Drive Type – Hydraulic power pack

## Customized options available

- Guarding
- Fixed base
- Battery driven
- We have 'off the shelf' machines, that can be further customized, or we can create a new solution for your specific needs.

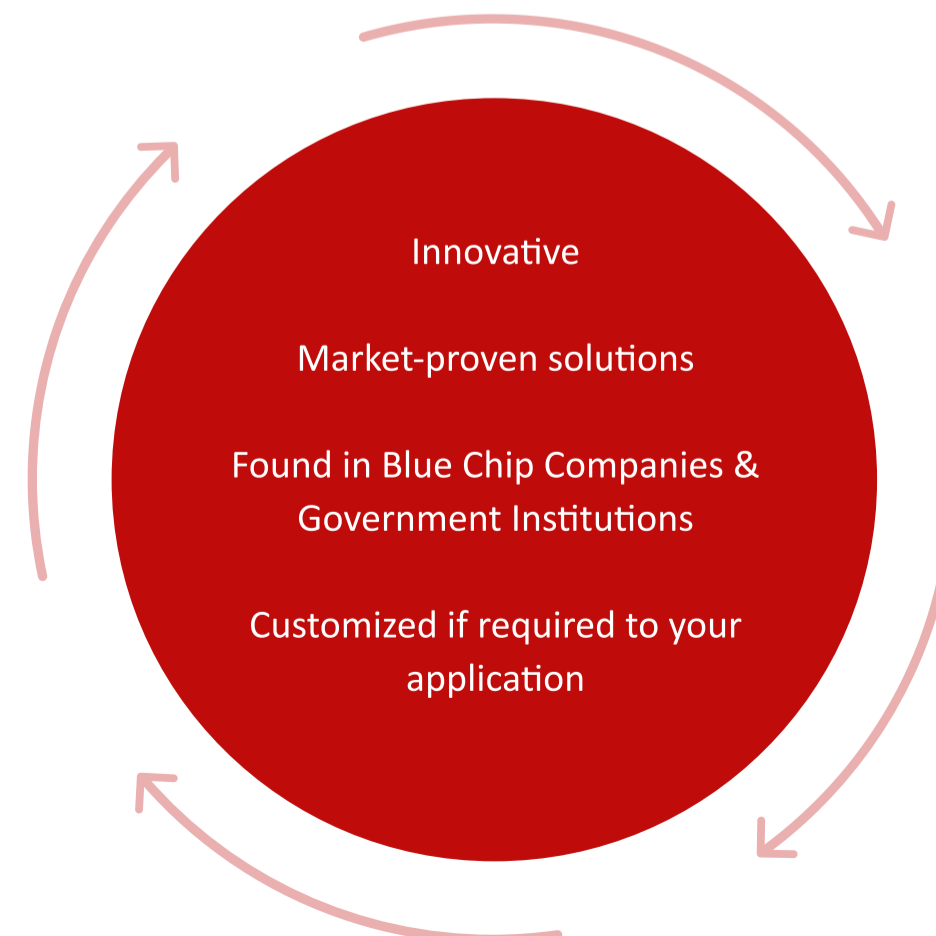

1

2

3

4

5

6

A

B

C

D

E

F

G

H

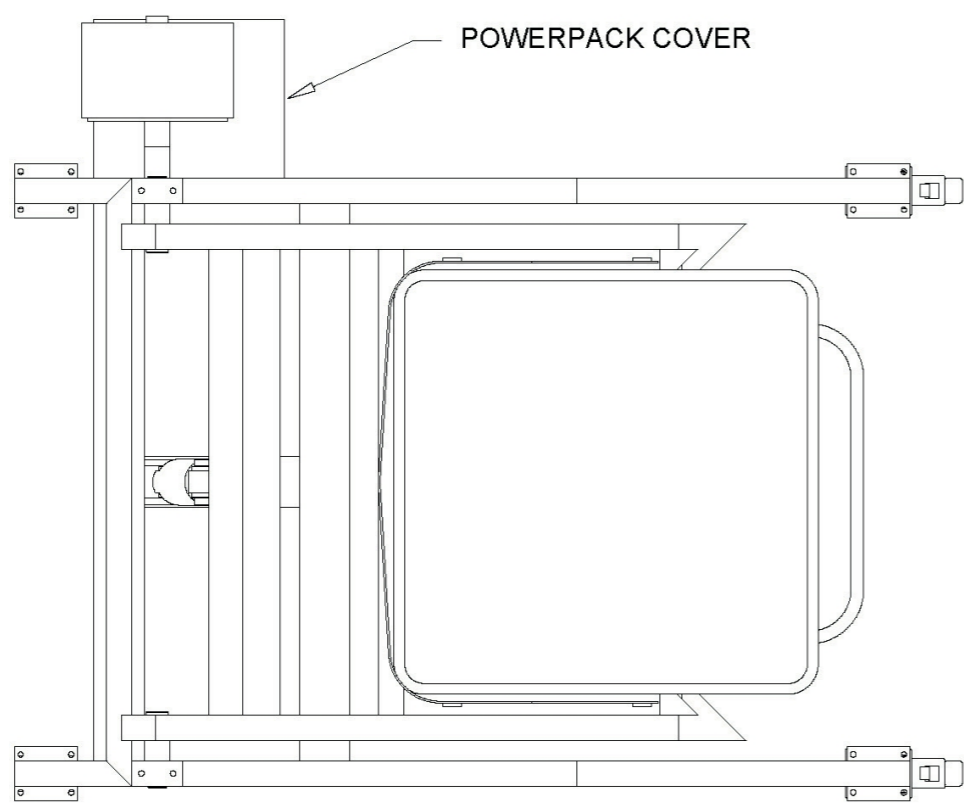

ISCA  
Stainless Steel Fabrication



**PROPRIETARY AND CONFIDENTIAL**  
The information contained in this drawing is the sole property of ISCA  
Any reproduction, in part or as a whole, without the written permission of ISCA is prohibited.

Unless otherwise specified:  
Dimensions are in inches [mm]  
Surface finish:  
Tolerances: imperial [metric(±15)]  
Linear: x.xx 0.2 (.xxx 0.01)  
Angular: xx' 010

A

B

C

D

E

F

G

H

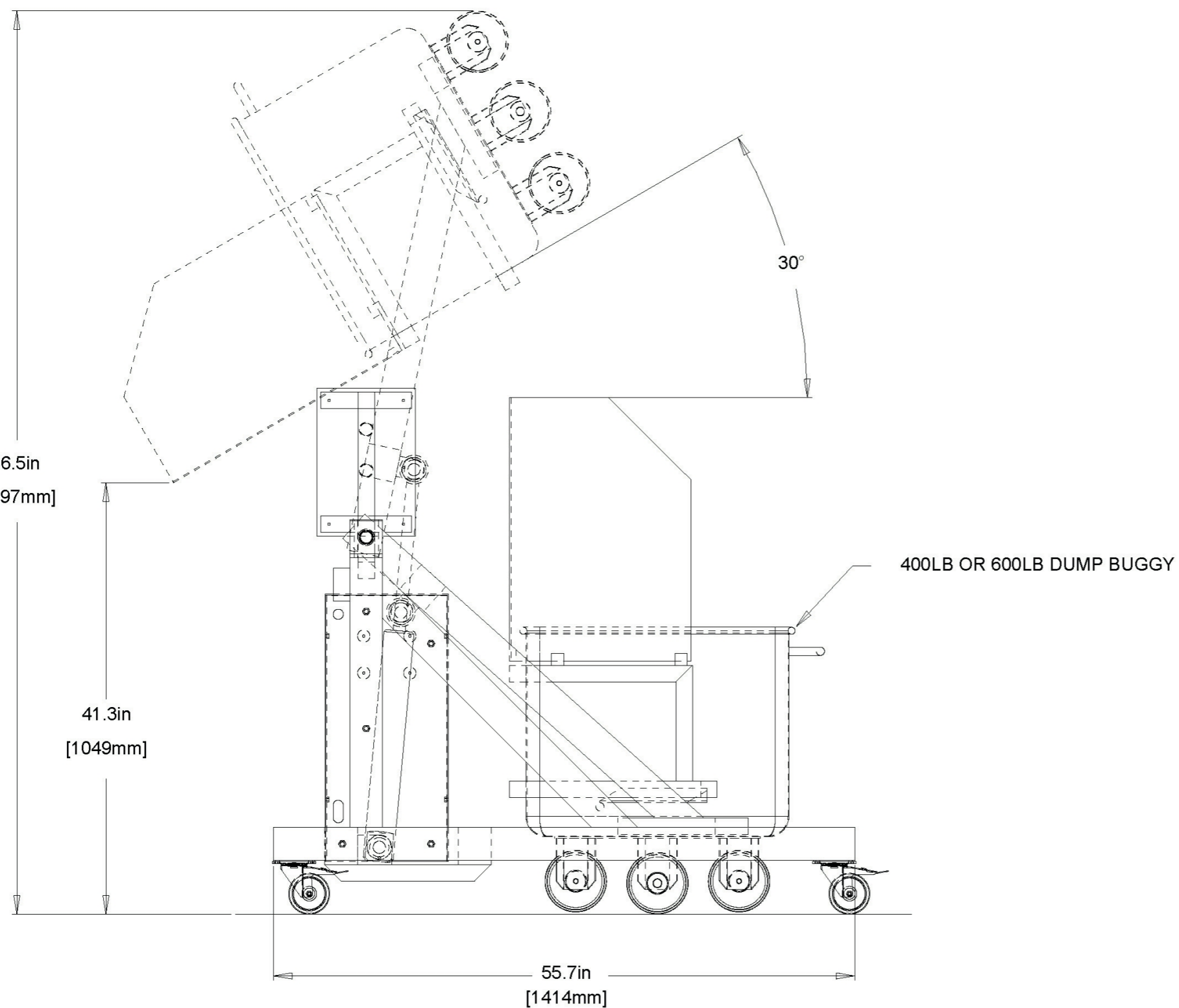
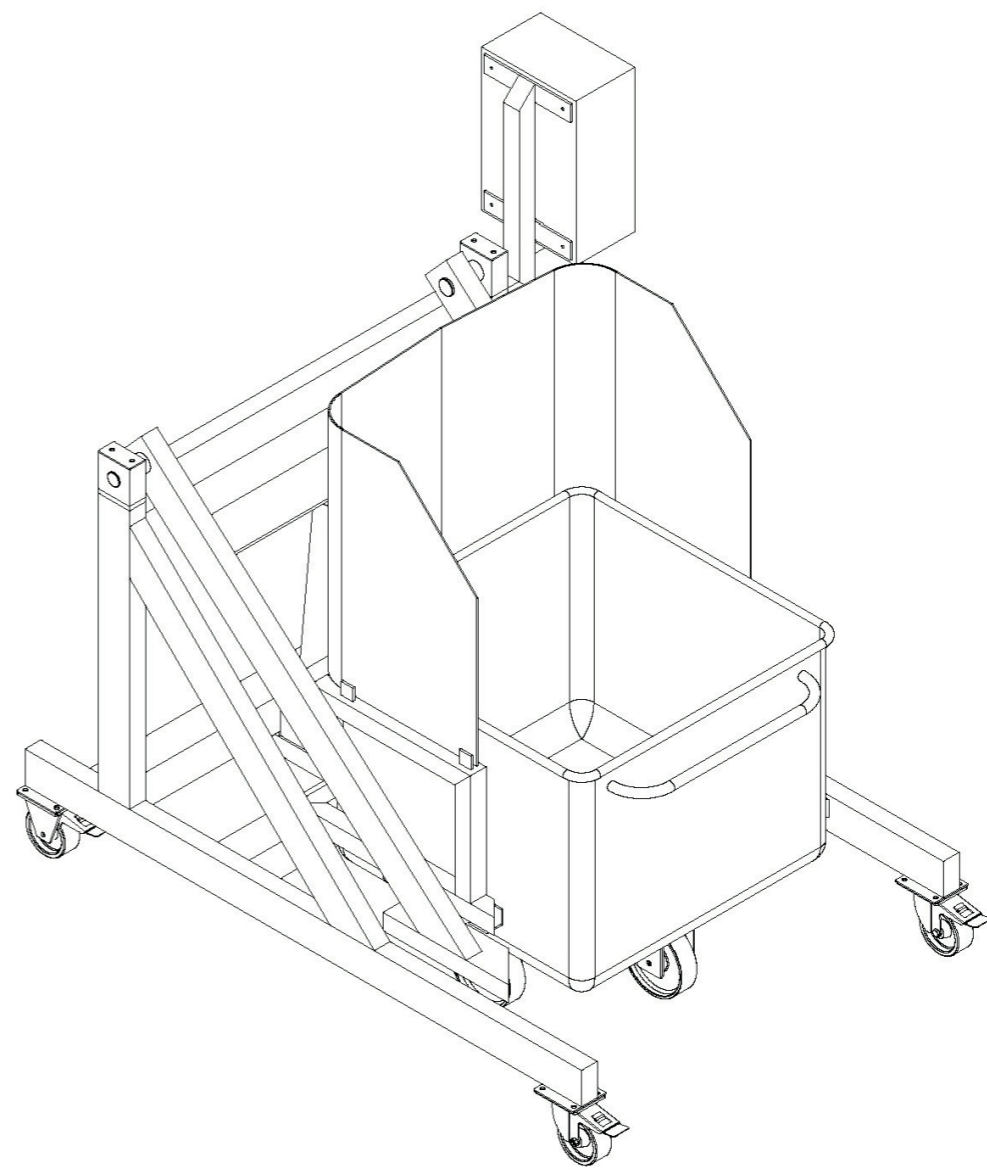
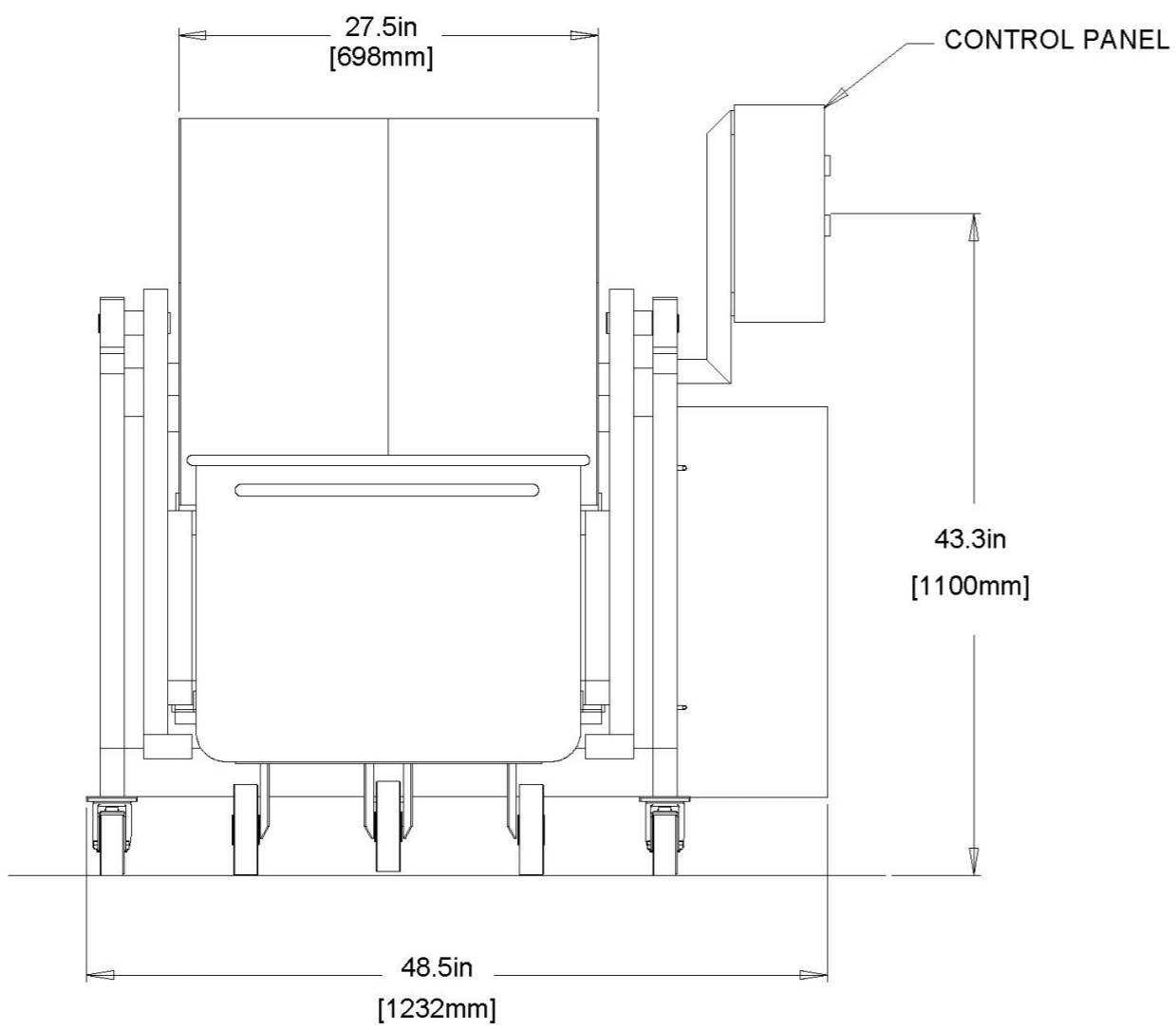

product no:

ISCA- Dump Buggy Tipper

1

2

3

4

5

6



Wash



Store



Protect & Identify



# ISCA Dump Buggy Solutions

Weigh



Lift + Tip



Mix



Transport



Transfer

