

## Features

- Battery-powered
- Telescopic mast
- Compatible with 200lb (120L), 400lb (200L) and 600lb (400L) dump buggies.
- Max lift height = 90"
- Lift capacity 550 lb (250 kg)
- Overall height = 75"
- Mobile
- 304 stainless steel
- Welded construction throughout
- Single phase charging unit

## Technical Specifications

- Battery powered
- Control circuit – 24V AC
- Electrical rating – IP65
- Drive Type – Braked motor gearbox + roller chain (simplex 3/4" chain)
- Lift speed – 32 ft/min (10 m/min)

## Customized options available

- ISCA can assist you in lifting and dumping any container; at any height, into any vessel, safely and efficiently.
- We have 'off the shelf' machines, that can be further customized, or we can create a new solution for your specific needs.



1 2 3 4 5 6

A

B

C

D

E

F

G

H

A

B

C

D

E

F

G

H



ISCA  
Stainless Steel Fabrication

**PROPRIETARY AND CONFIDENTIAL**  
The information contained in this drawing is the sole property of ISCA.  
Any reproduction, in part or as a whole, without the written permission of ISCA is prohibited.

Unless otherwise specified:  
Dimensions are in inches [mm]  
Surface finish:  
Tolerances: imperial [metric(±15)]  
Linear: x.xx 0.2 (.xxx 0.01)  
Angular: xx' 010

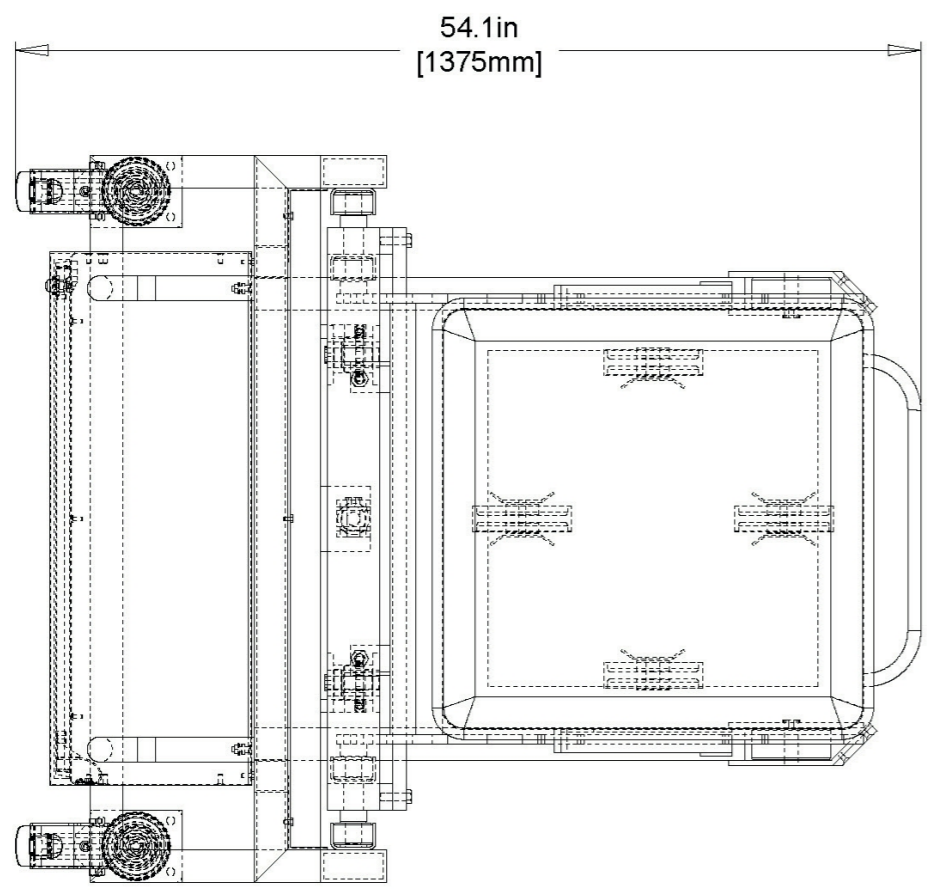
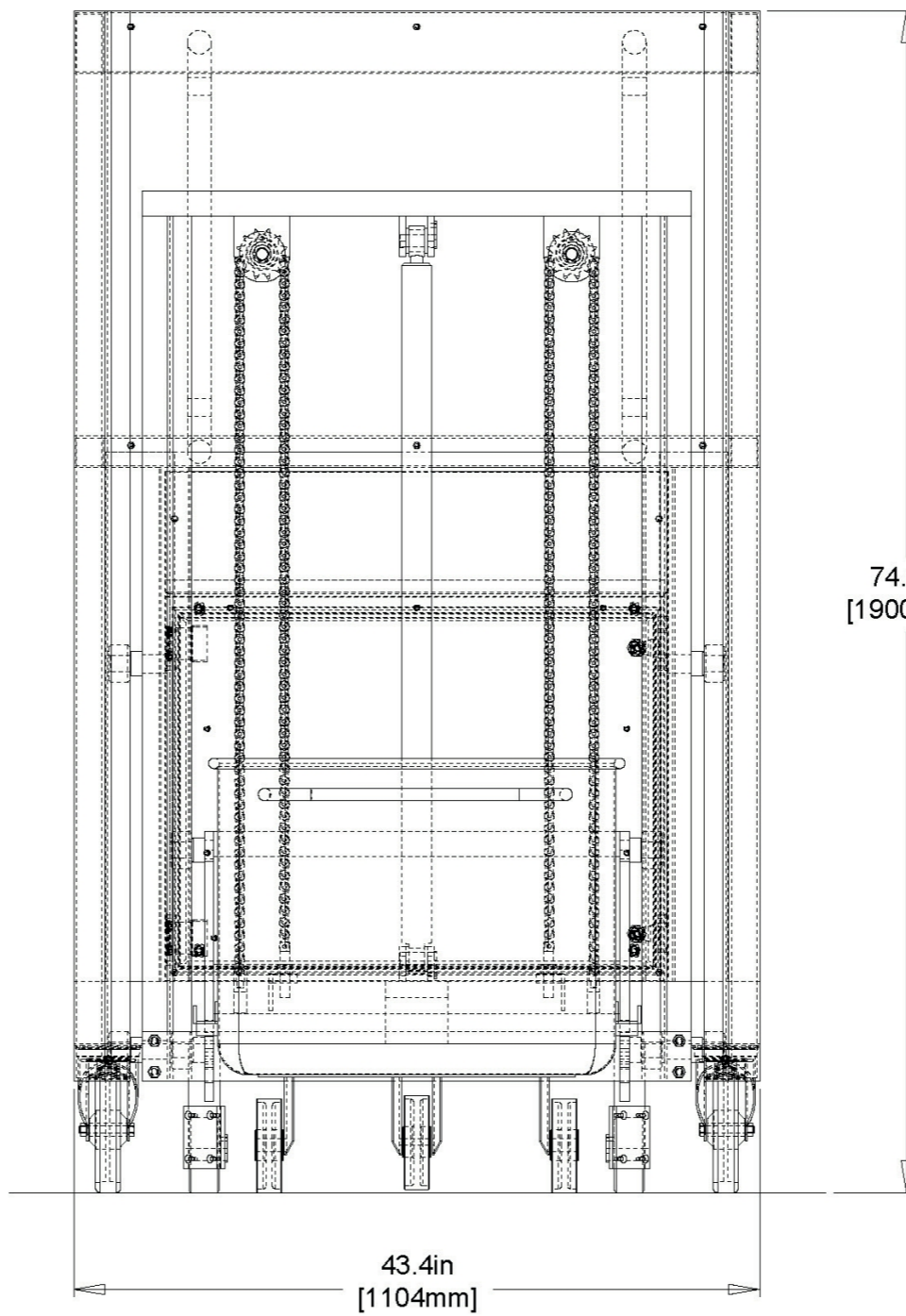
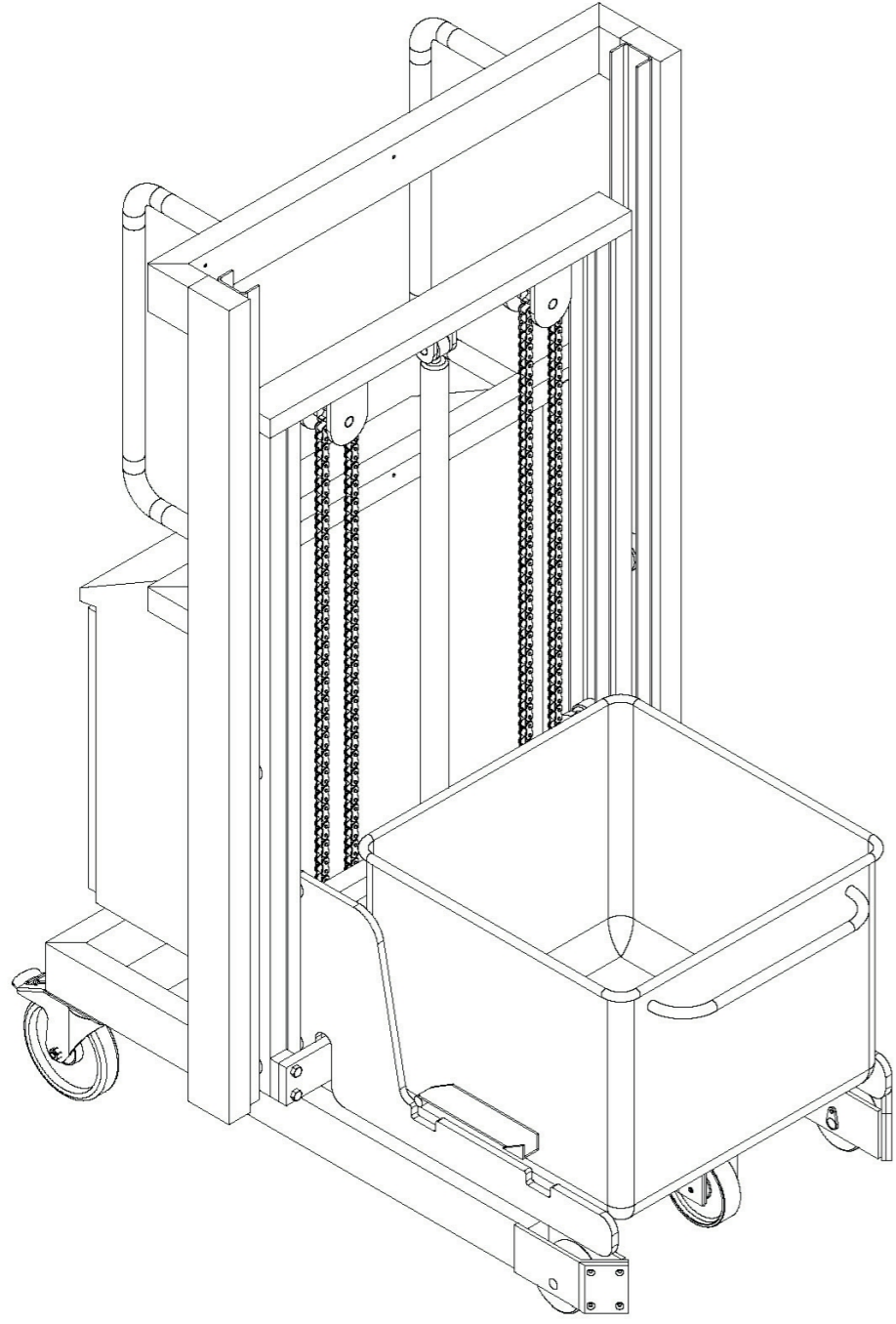

1 2 3 4 5 6

74.8in  
[1900mm]

43.4in  
[1104mm]

54.1in  
[1375mm]

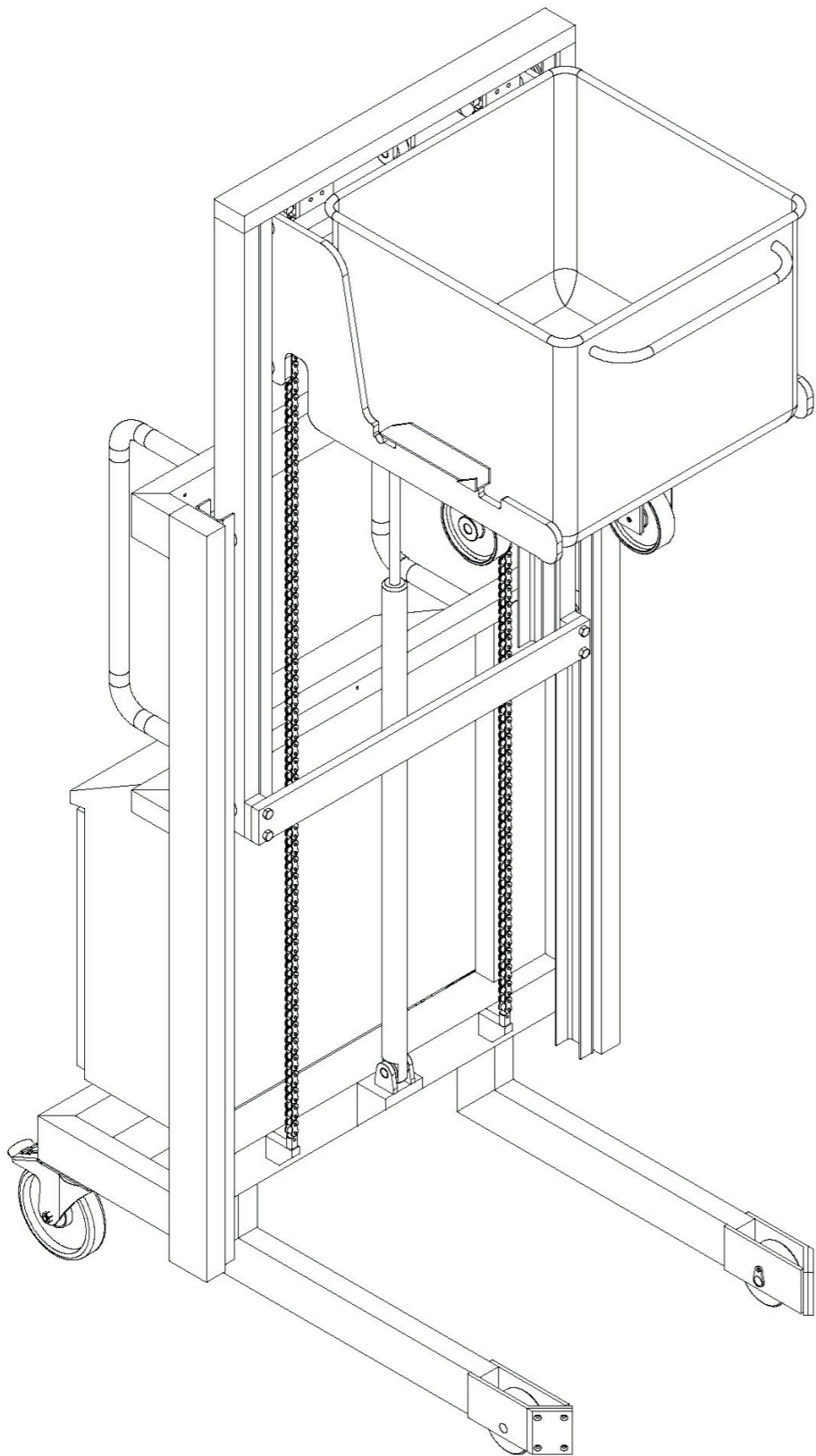
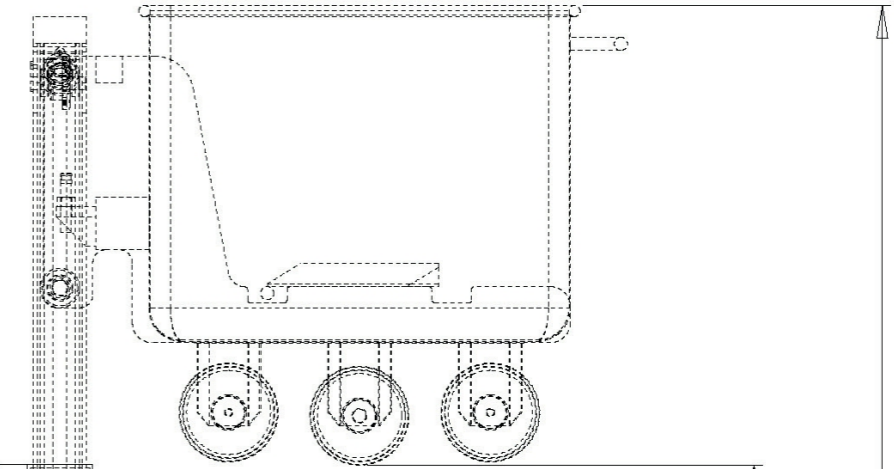

CONTROL PANEL

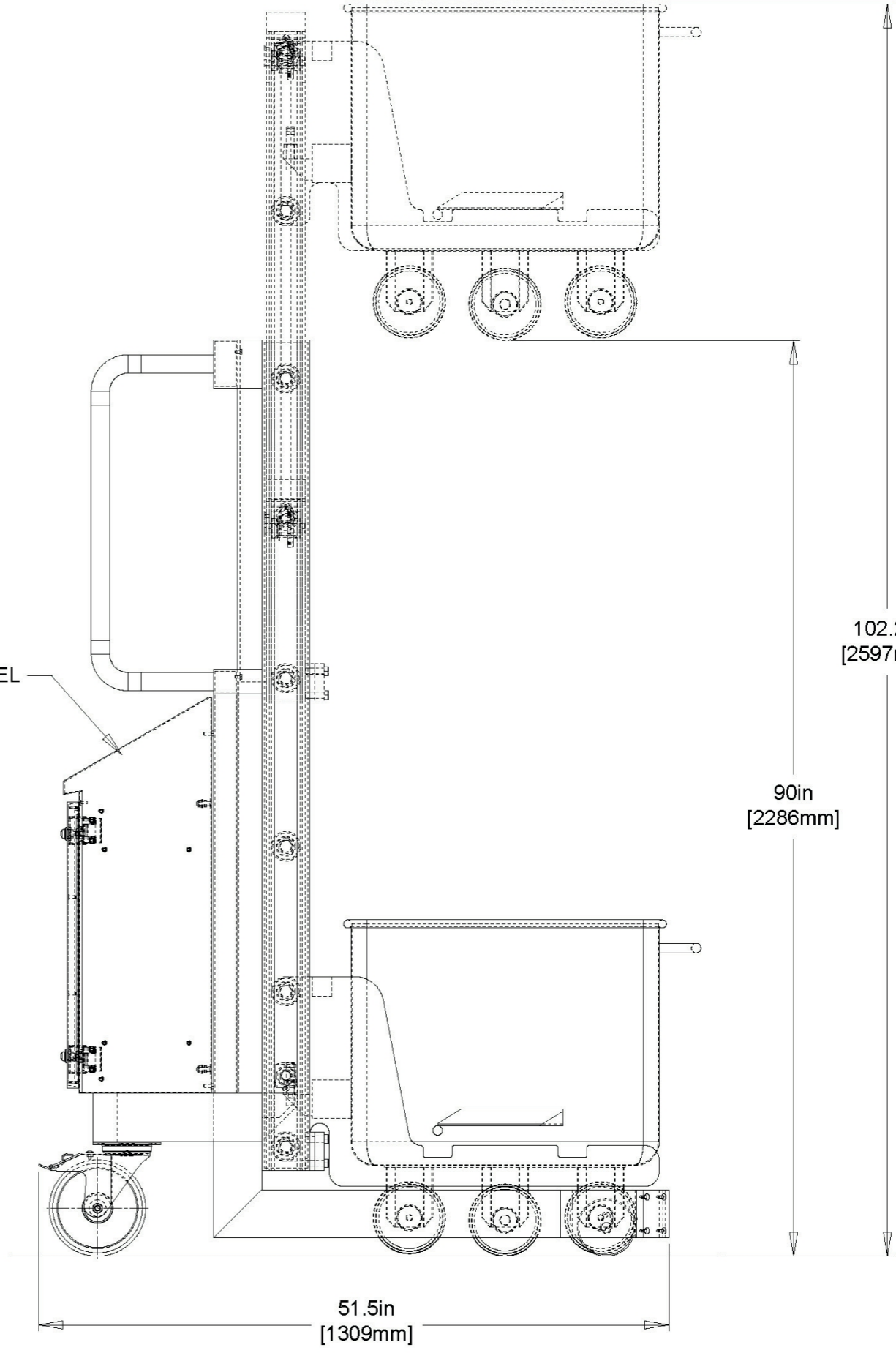

102.2in  
[2597mm]

90in  
[2286mm]

51.5in  
[1309mm]

product no:  
**ISCA- Dump Buggy Stacker**



Wash



Store



Protect & Identify



# ISCA Dump Buggy Solutions

Weigh



Transfer



Lift + Tip



Mix



Transport

