

Features

A Stainless steel Dump Buggy Pneumatic Wash Frame for 200, 400 + 600lb dump buggies.
The unit lifts dump buggies into a horizontal position to assist cleaning inside and underneath the buggy.
This unit is a pneumatic air power operation.

Features:

- Single or double unit system available
- Fully welded assembly
- Compact free-standing system
- Corrosion resistant – Full wash-down design
- IP65 rated

Technical Specifications

- Material – 304 grade stainless steel
- Tipping angle – 100 degrees (10 degrees past horizontal)
- Tip height – 36"
- Power – Air
- Rating – IP65
- Lifting capacity – 150lb (max for each empty buggy)

Customized options available

- Mobile system

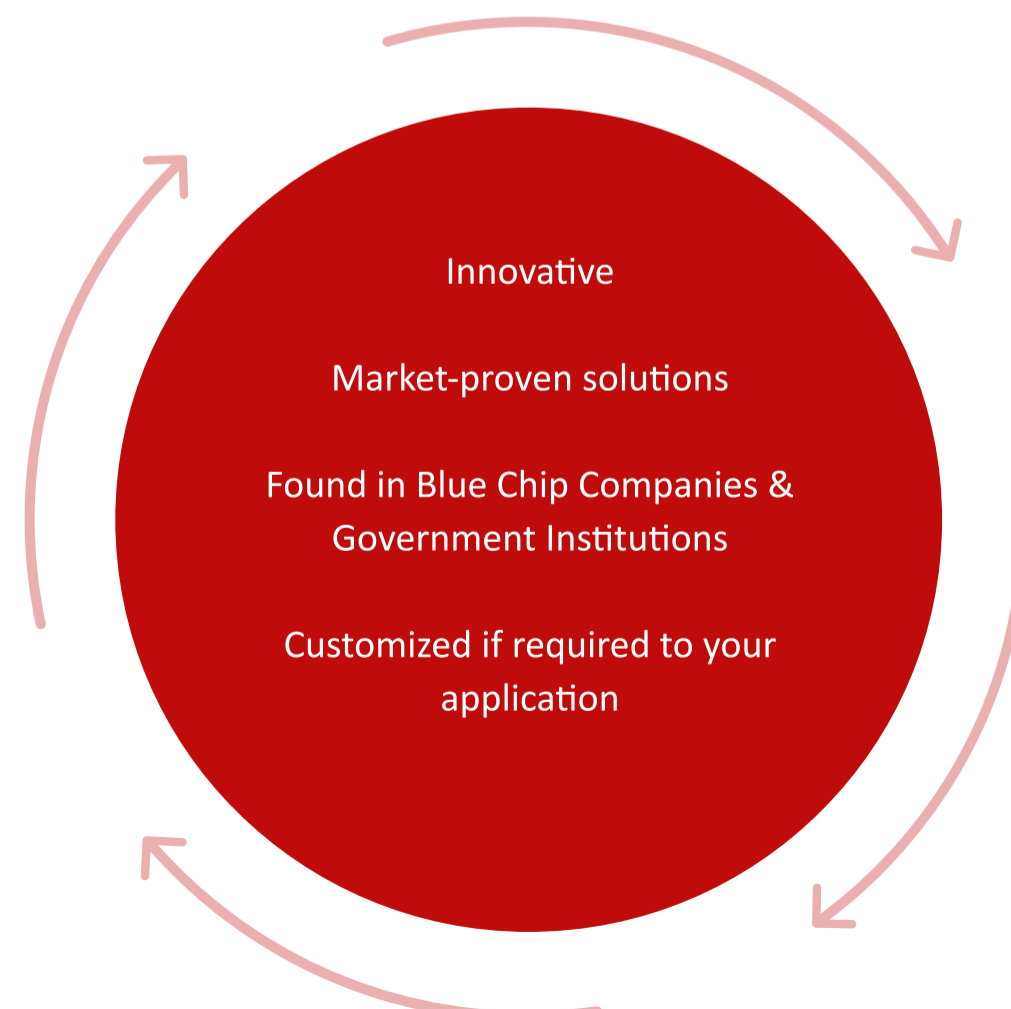

1 2 3 4 5 6 7 8

A

B

C

D

E

F

A

B

C

D

E

F

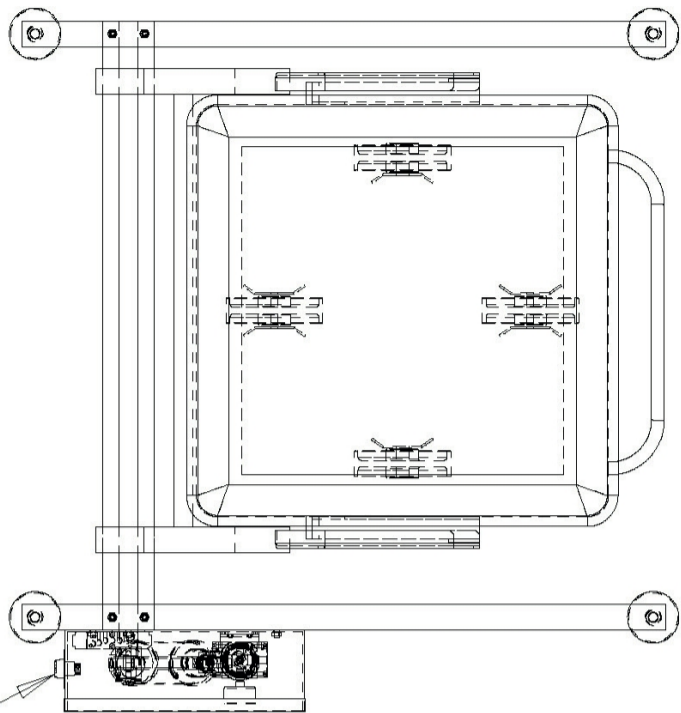
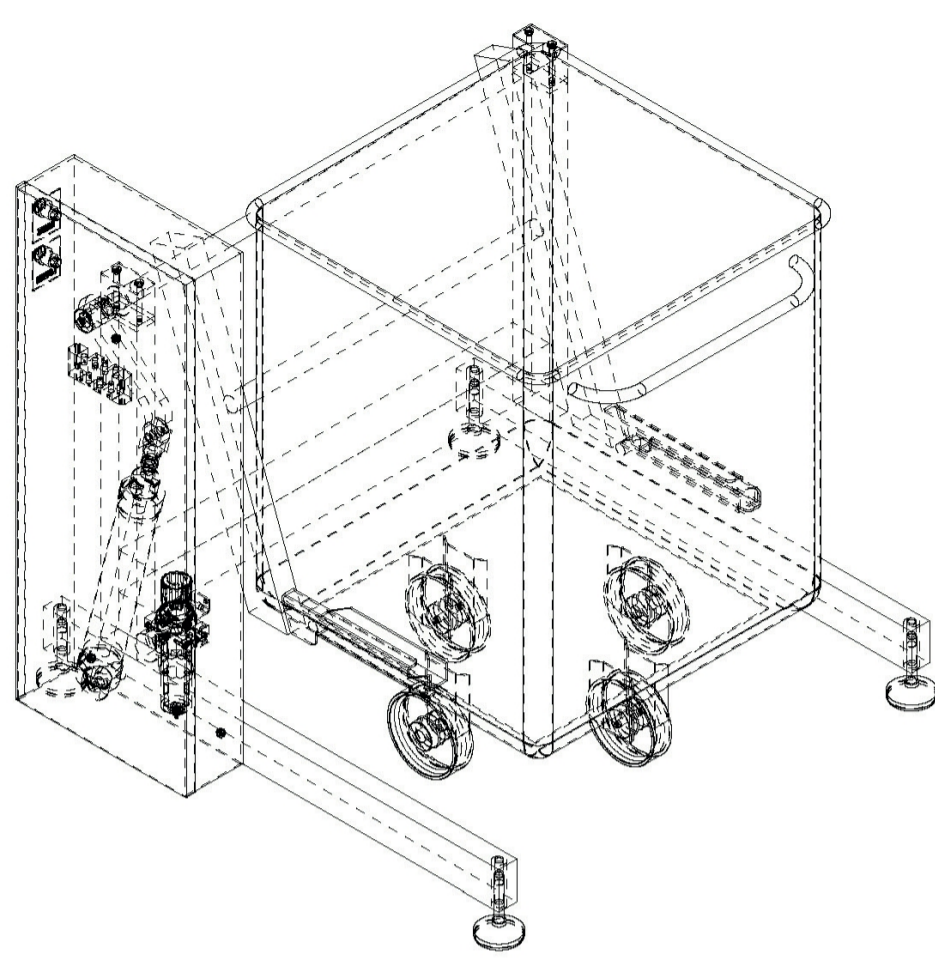

PUSH BUTTONS

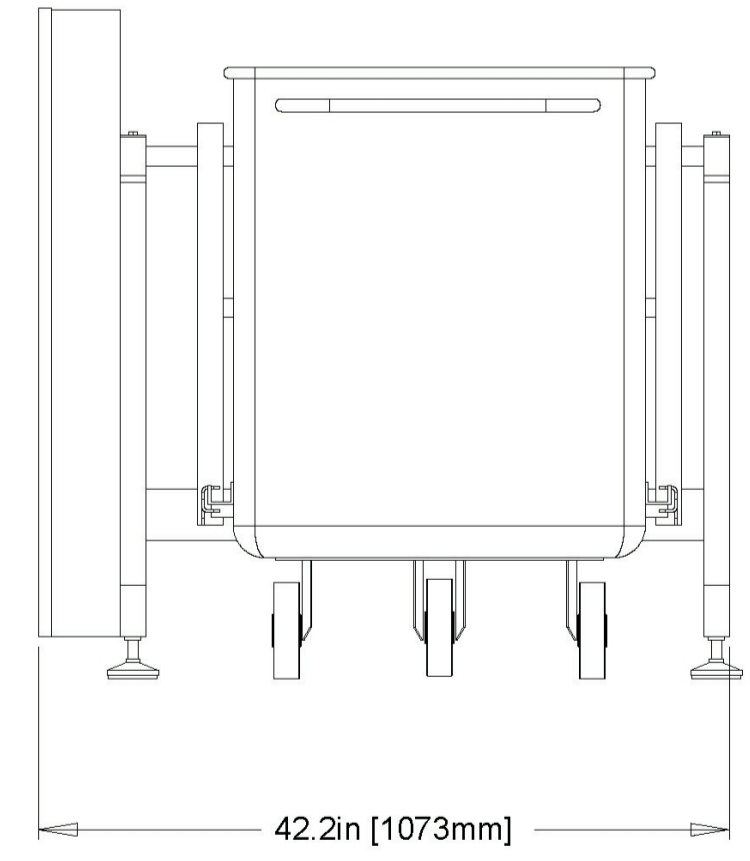
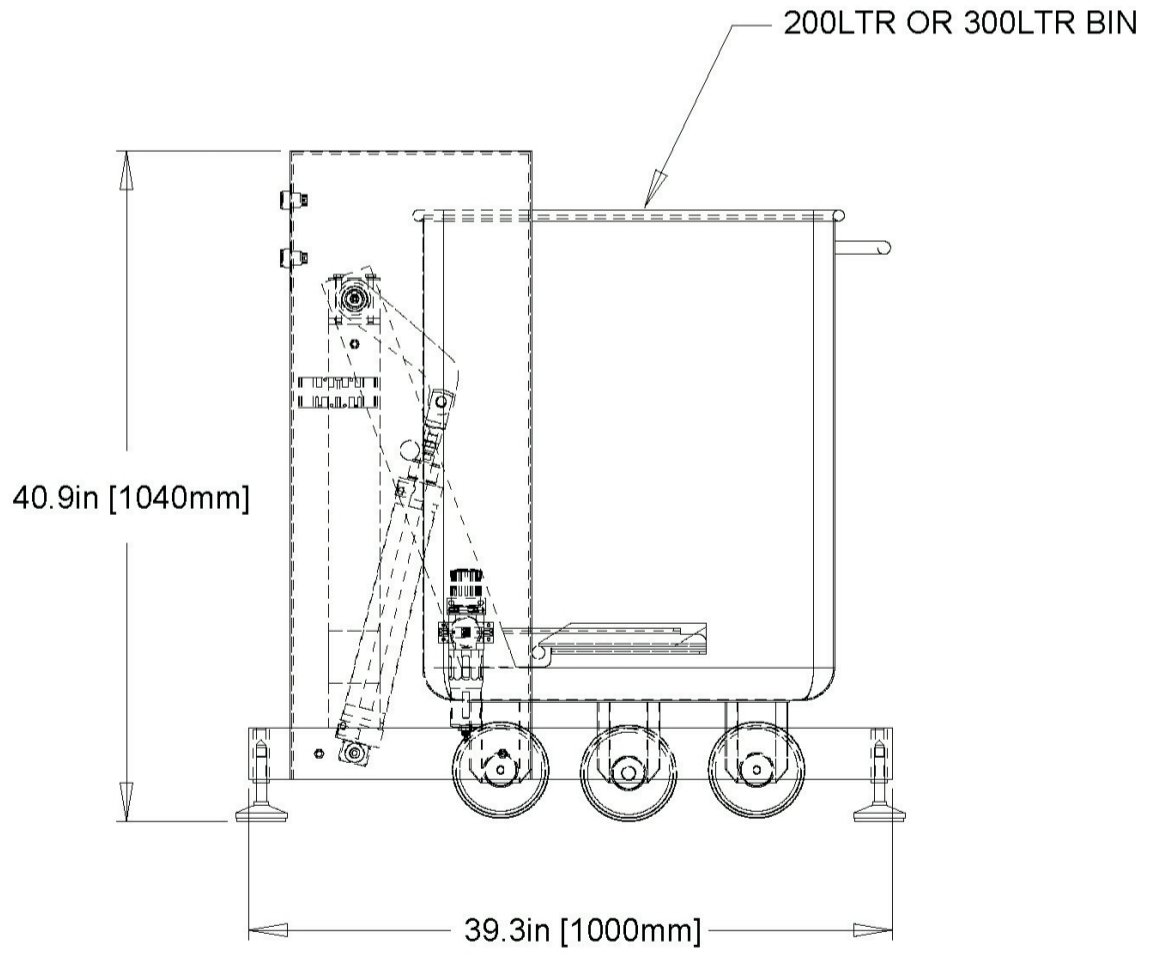
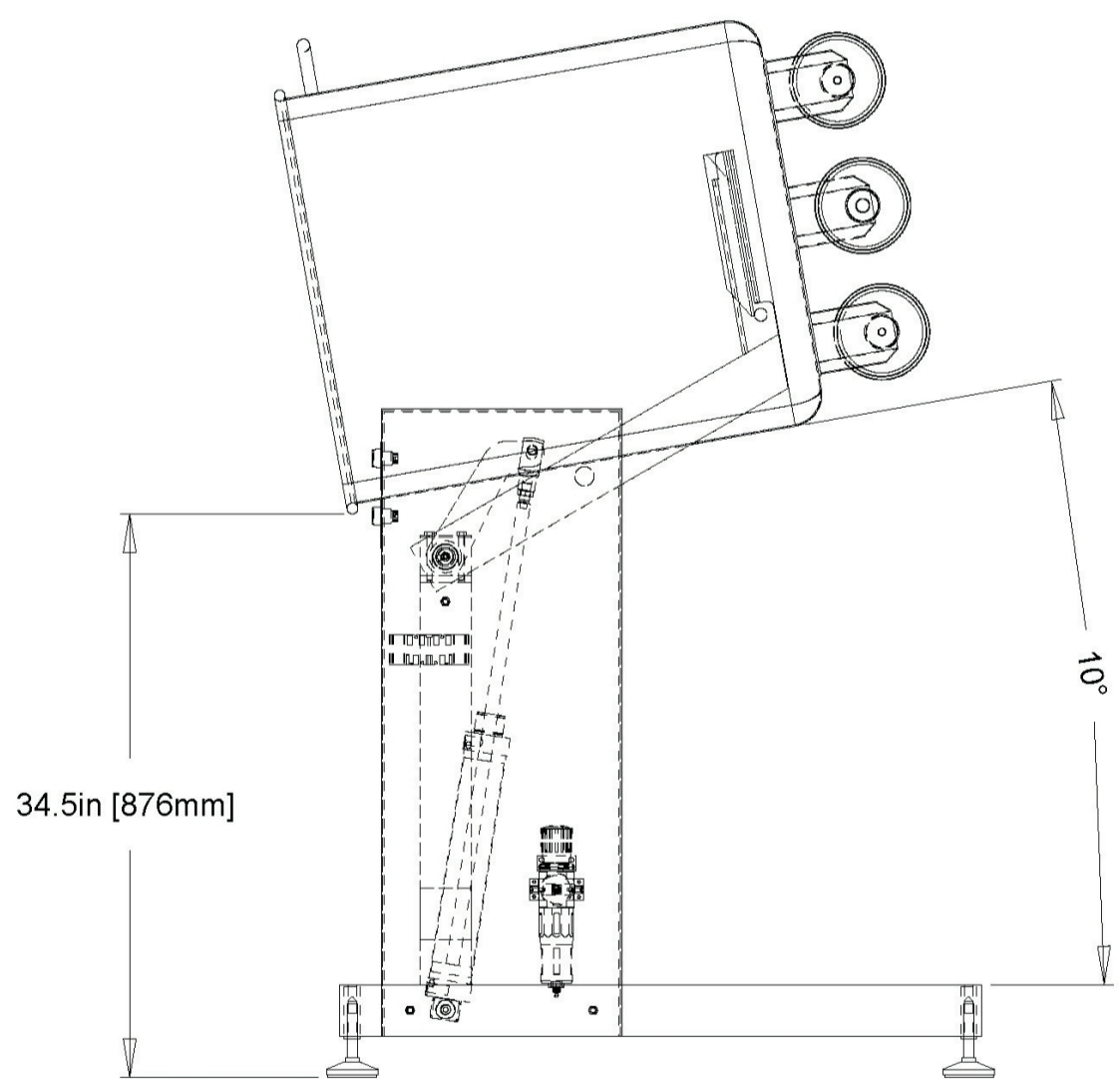

PROPRIETARY AND CONFIDENTIAL
 The information contained in this drawing is the sole property of ISCA
 Any reproduction, in part or as a whole, without the written permission of ISCA is prohibited.

Unless otherwise specified:
 Dimensions are in inches [mm]
 Surface finish:
 Tolerances: imperial [metric(±15)]
 Linear: x.xx 0.2 (.xxx 0.01)
 Angular: xx' 010

productno:
ISCA - Dump Buggy Wash Frame - Single

1 2 3 4 5 6 7 8

Wash



Store



Protect & Identify



ISCA Dump Buggy Solutions

Weigh



Transfer

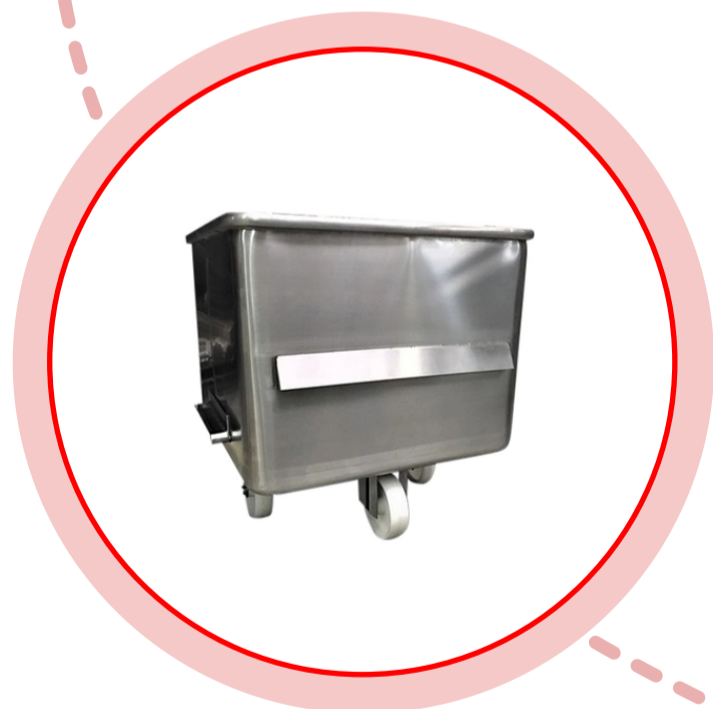

Lift + Tip



Mix



Transport

