

Features

A stainless steel boot storage rack for the air drying and storage of production footwear, with lockable boot holders.

Features:

- Stainless steel Grade 304
- Adjustable leg height
- Lockable
- Full wash-down design

Technical Specifications

-Stainless steel Grade 304

Customized options available

Fully customizable solutions are available.

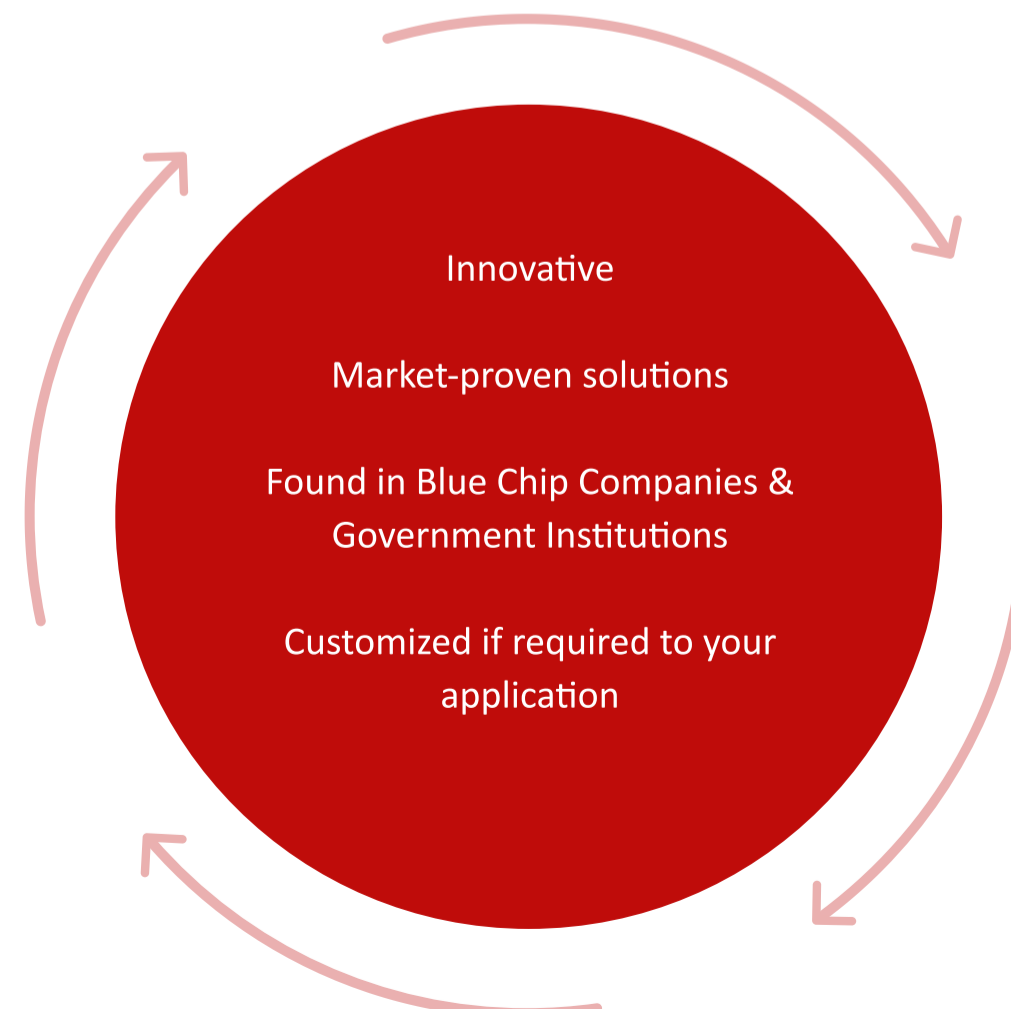

1 2 3 4 5 6 7 8

A

B

C

D

E

F

A

B

C

D

E

F

ISCA
Stainless Steel Fabrication



PROPRIETARY AND CONFIDENTIAL

The information contained in this drawing is the sole property of ISCA
Any reproduction, in part or as a whole, without the written permission of ISCA is prohibited.

Unless otherwise specified:
Dimensions are in inches [mm]
Surface finish:
Tolerances: imperial [metric(±15)]
Linear: x.xx 0.2 (.xxx 0.01)
Angular: xx' 010

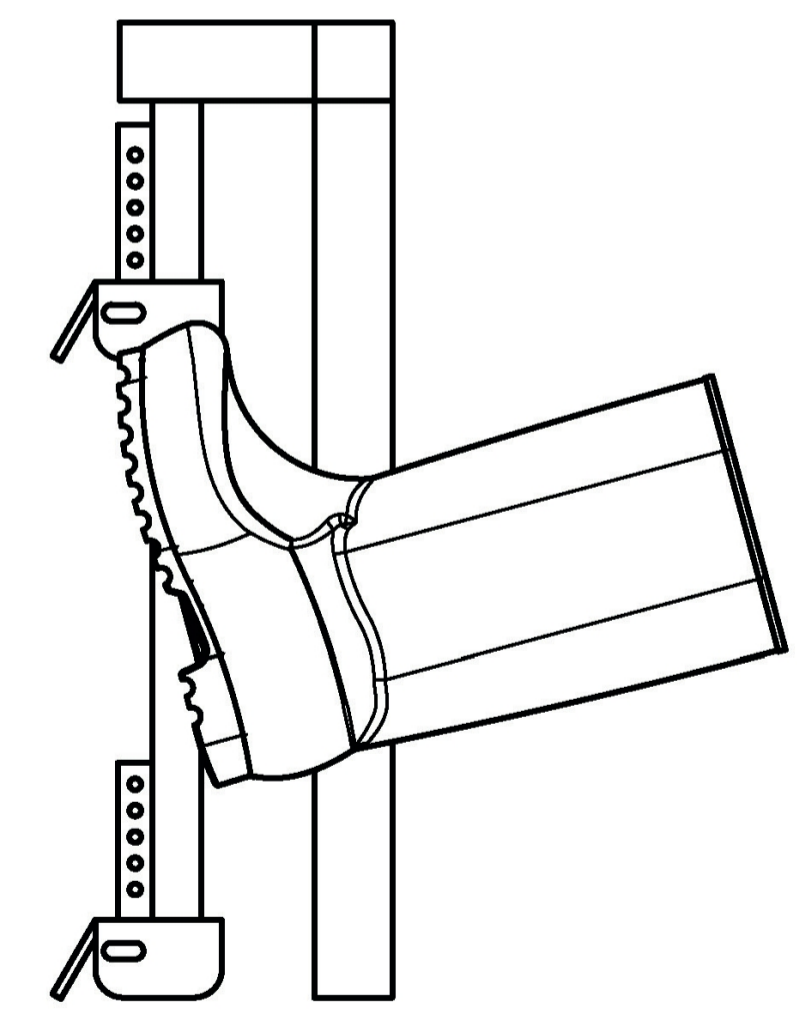
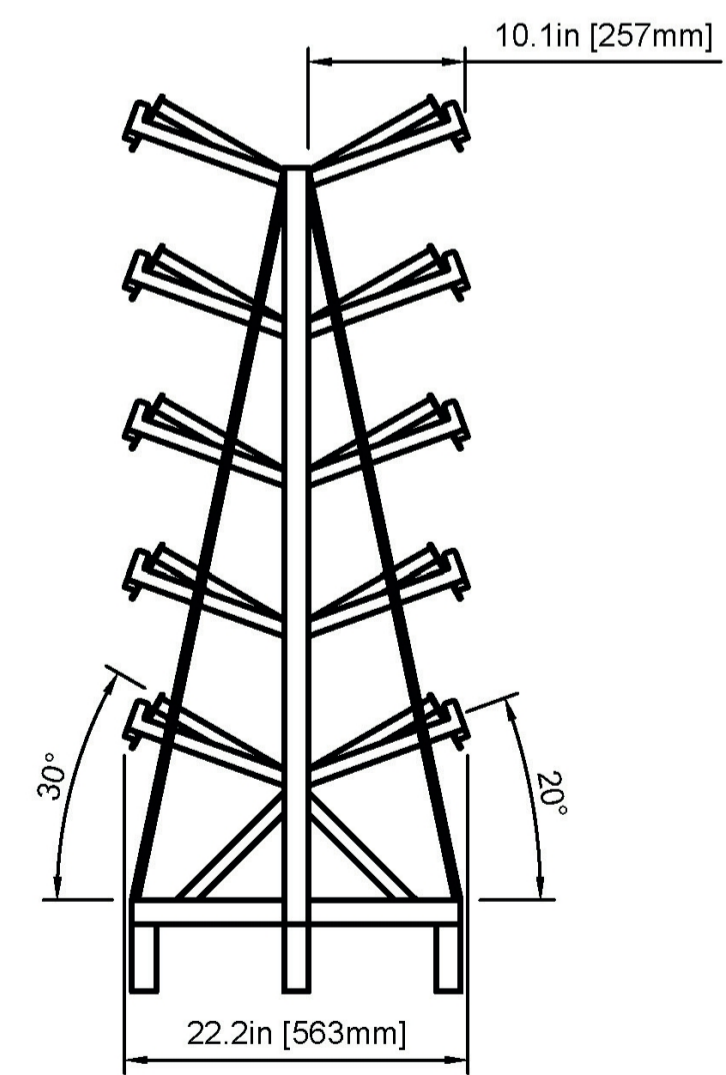
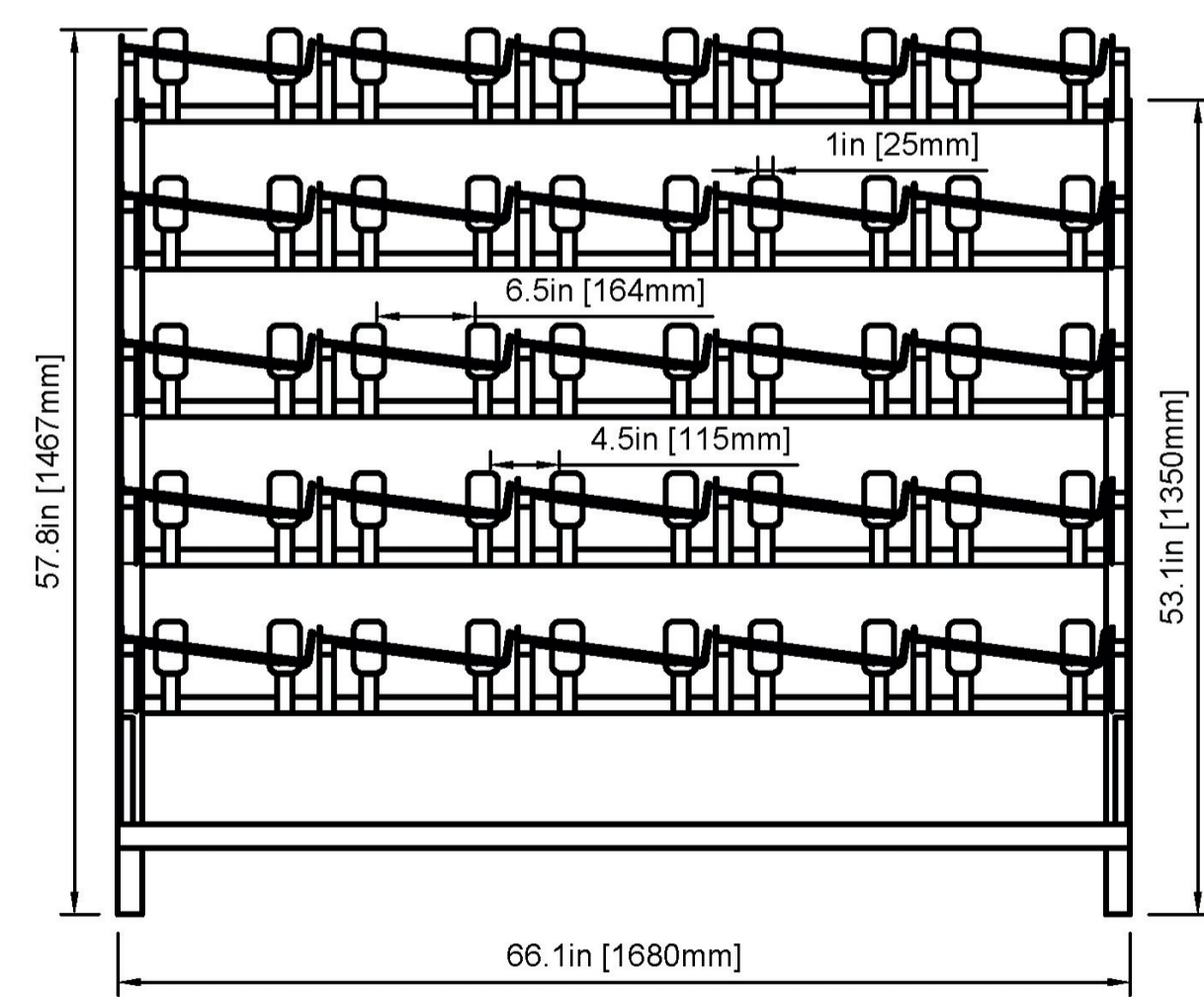
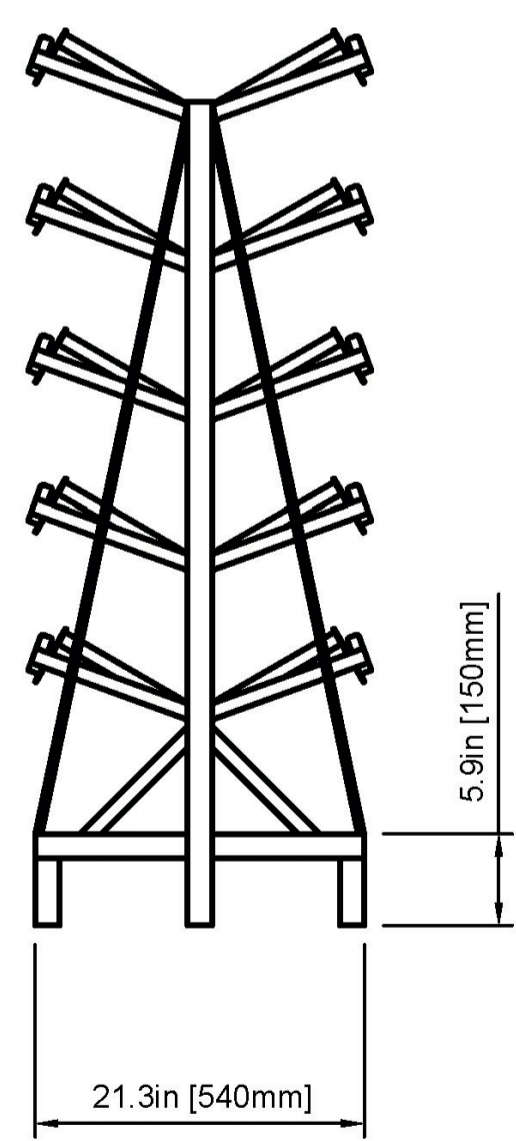
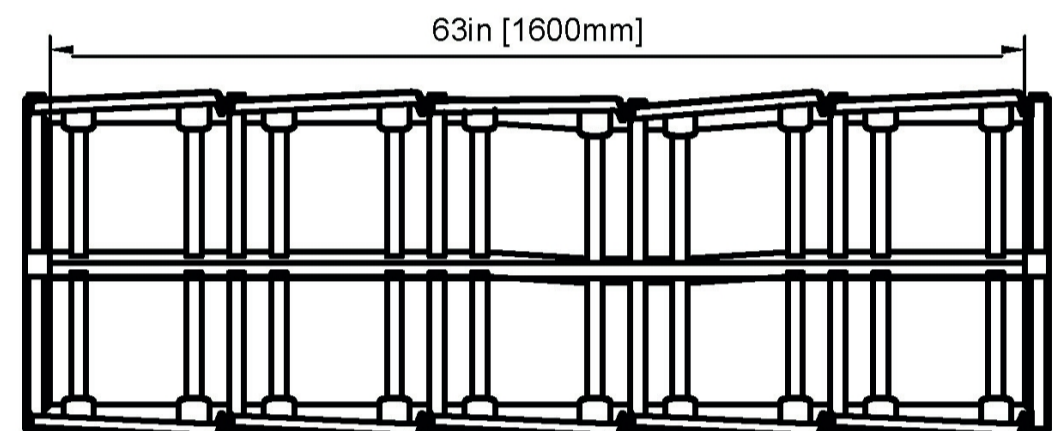
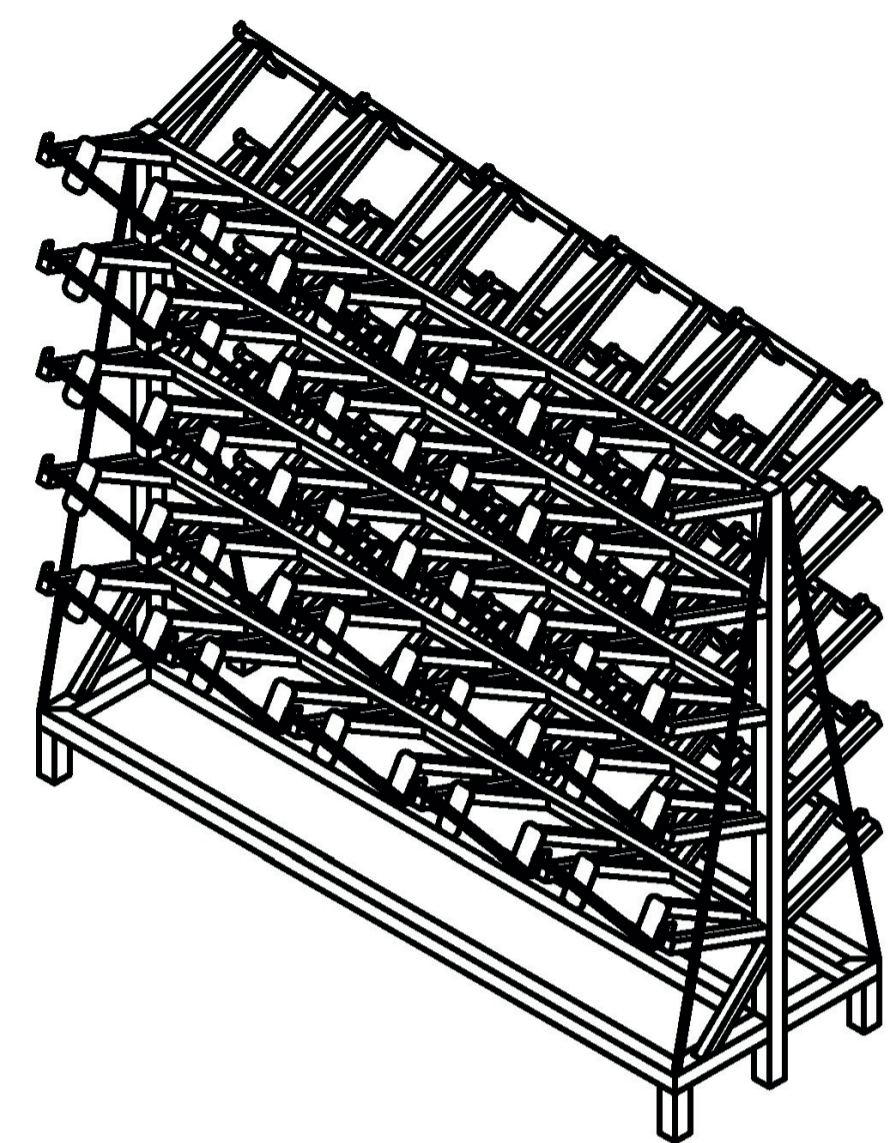

product no:

**ISCA - Lockable
Boot Rack**

1 2 3 4 5 6 7 8

Footwear storage

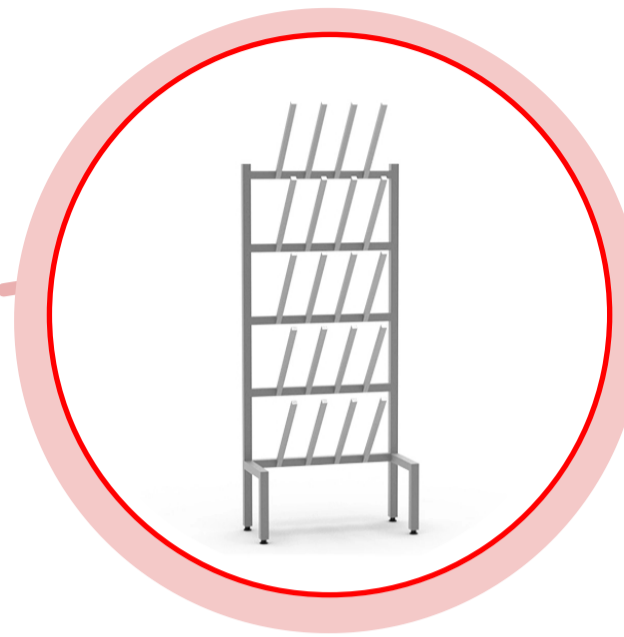

Workwear storage



**ISCA's
Hygiene
Equipment
Solutions**

Hygiene entrance stations



Manual bootwashers



Hand washing



Automatic boot washers