

Features

An automatic walk-through boot sole and calf washer for hygienic entrance corridors entering into production areas. For cleaning the sole and calf of footwear. Designed for a high throughput of personnel.

Features:

- Stainless steel Grade 304
- Welded body
- 5 brushes
- Adjustable leg height

Technical Specifications

- Dimensions: LxWxH 102.6" / 2606 mm x 39.3" / 1000 x 57.8" / 1491 mm
- Power supply 480V AC, 60 Hz, 16A
- Water supply 3/4"
- Wastewater outflow diam. 50mm

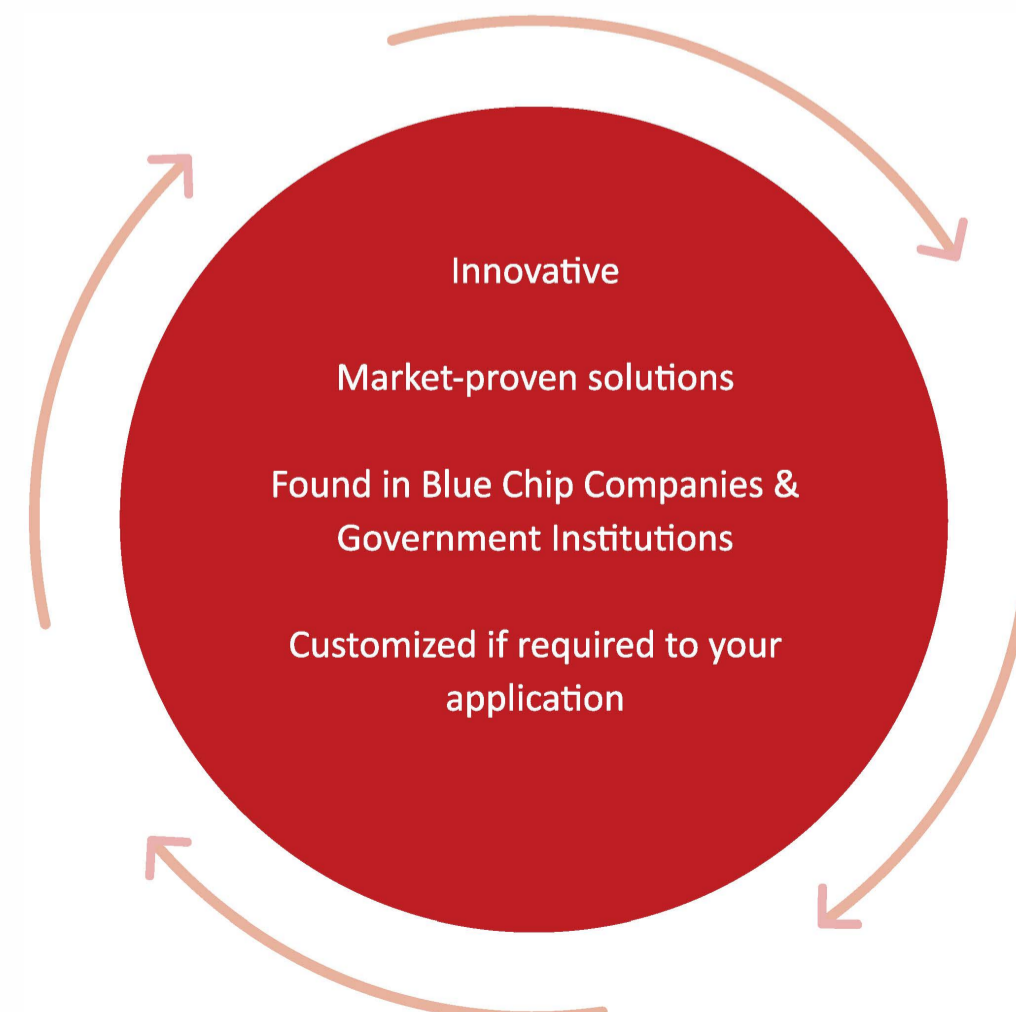

1 2 3 4 5 6 7 8

A

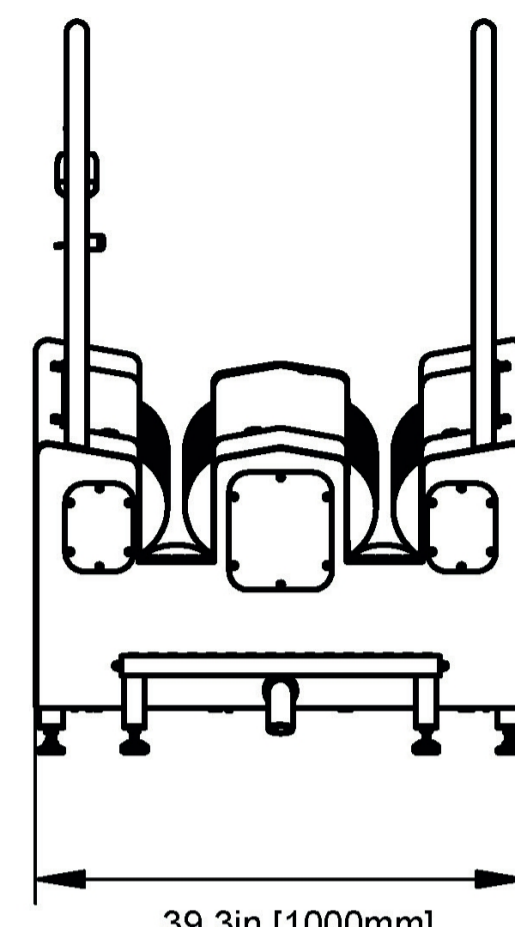

B

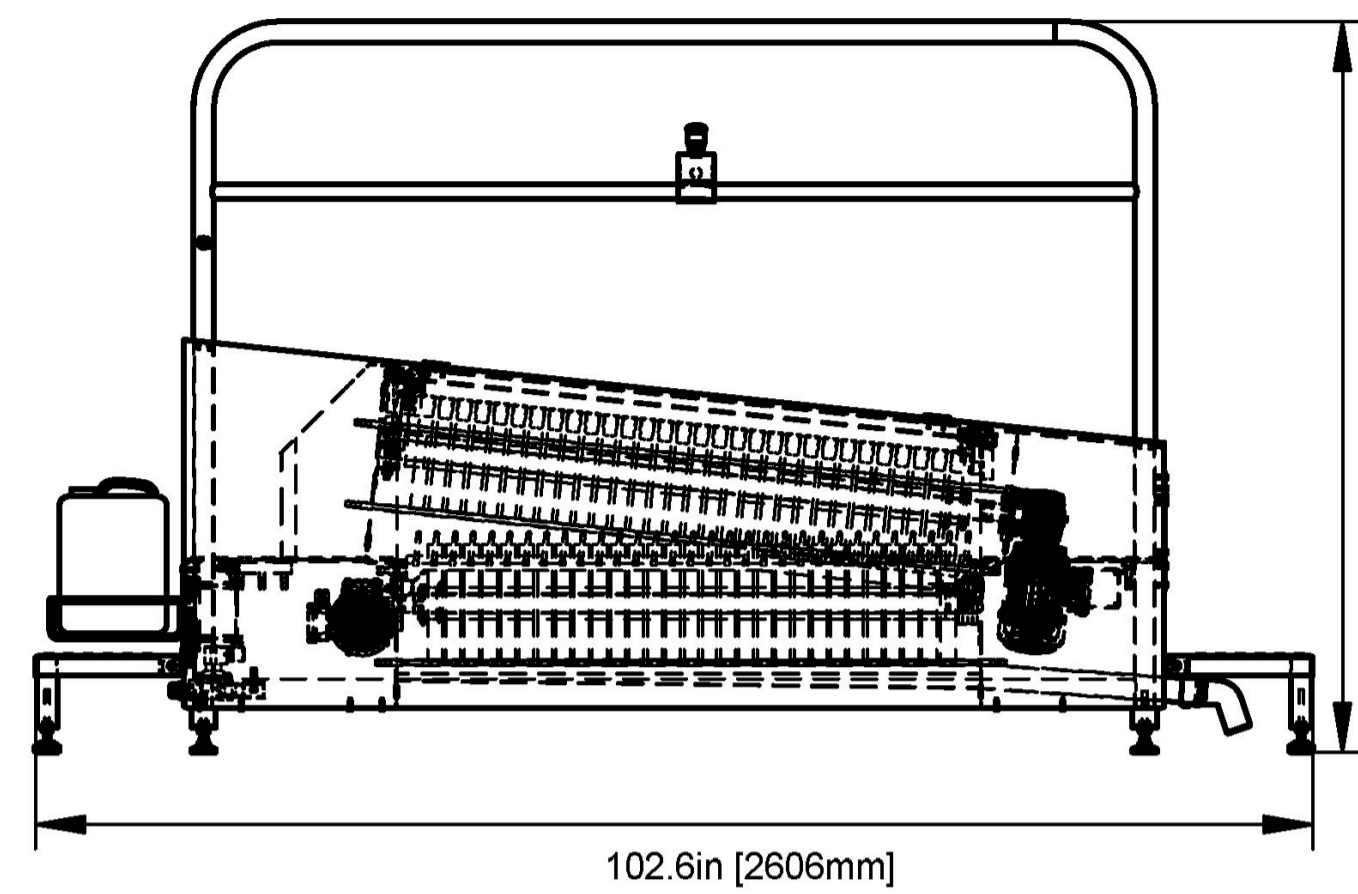

C

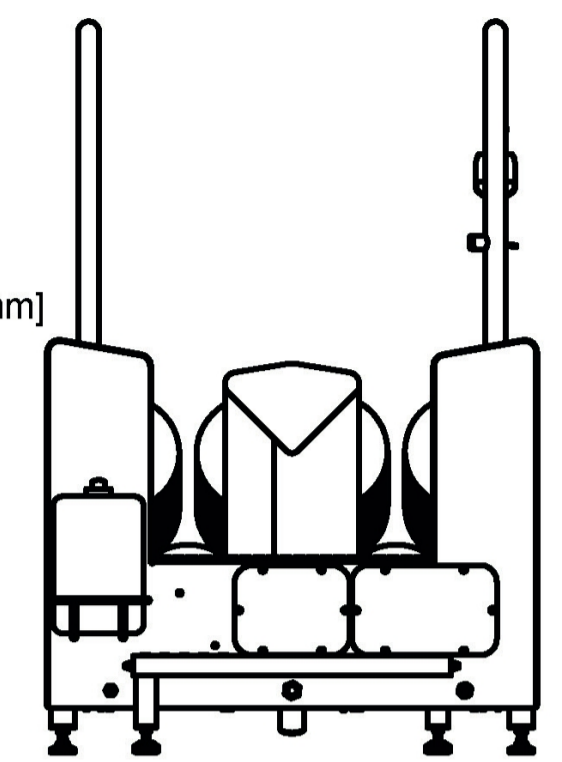

ISCA
Stainless Steel Fabrication



PROPRIETARY AND CONFIDENTIAL
The information contained in this drawing is the sole property of ISCA
Any reproduction, in part or as a whole, without the written permission of ISCA is prohibited.

Unless otherwise specified:
Dimensions are in inches [mm]
Surface finish:
Tolerances: imperial [metric(±15)]
Linear: x.xx 0.2 (.xxx 0.01)
Angular: xx' 010

D

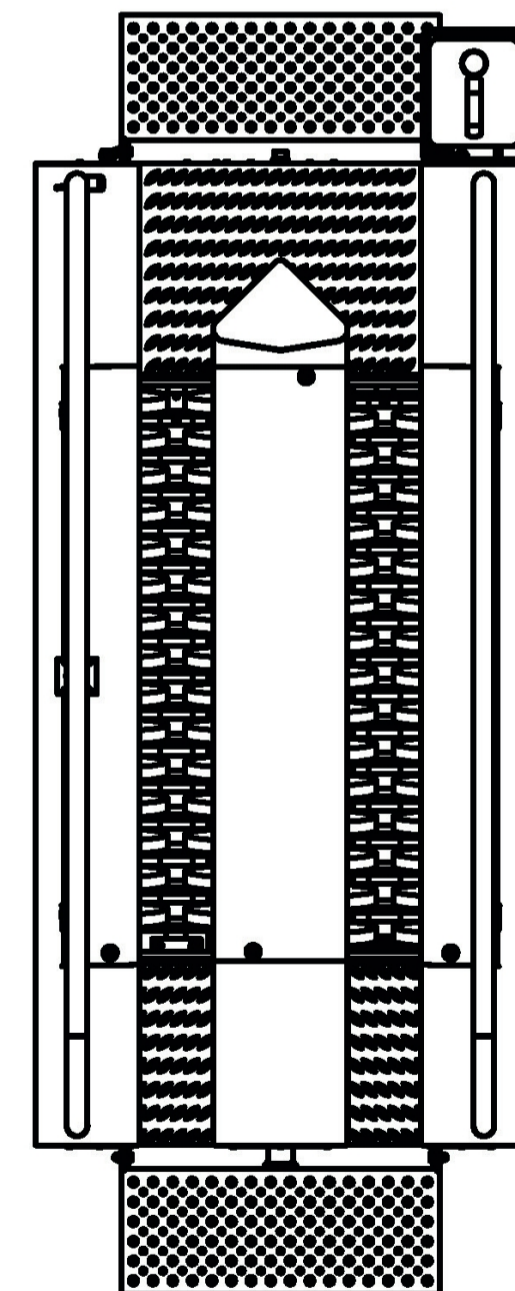

E

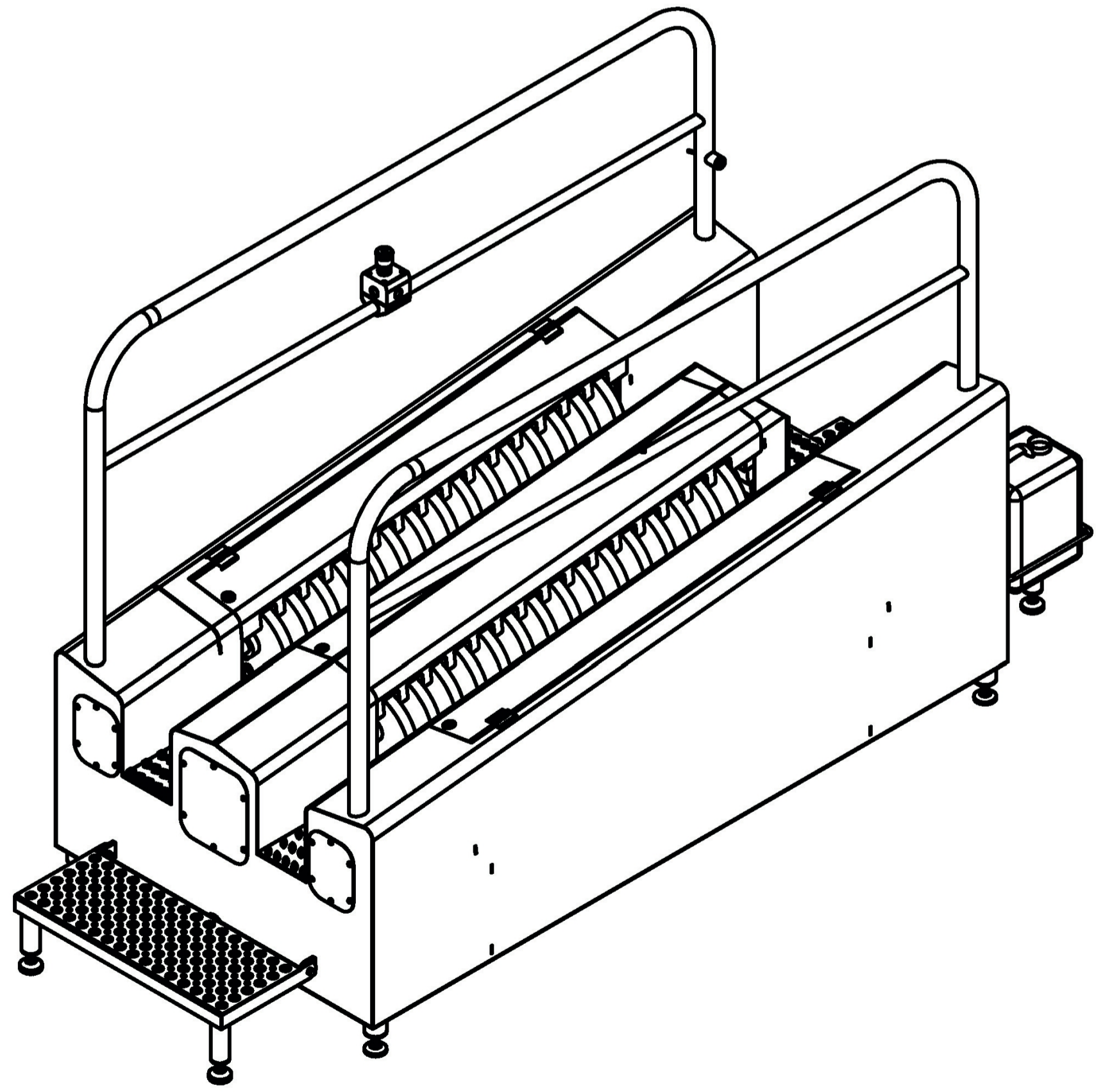

F

product no:
**ISCA - Walkthrough
Automatic Boot Sole and
Calf Washer**

1 2 3 4 5 6 7 8

Footwear storage

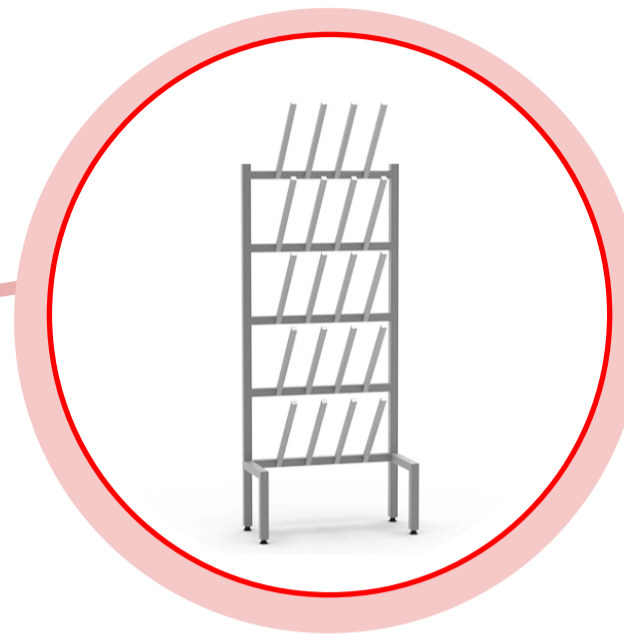

Workwear storage



**ISCA's
Hygiene
Equipment
Solutions**

Hygiene entrance stations



Manual bootwashers



Hand washing

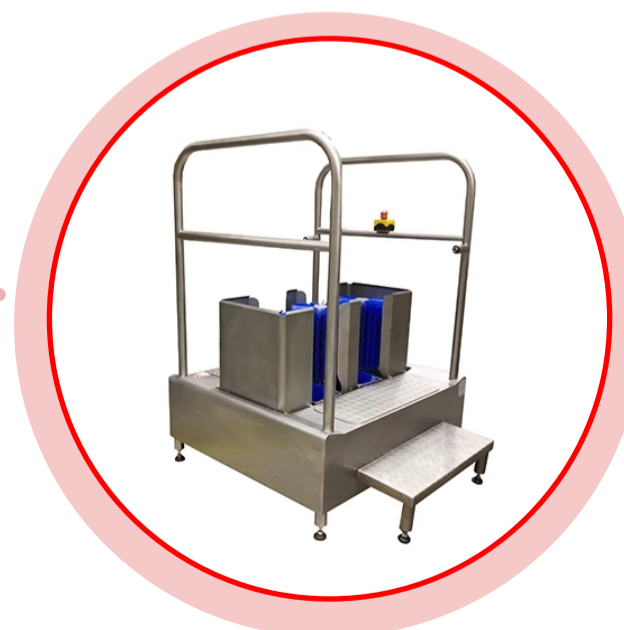

Automatic boot washers