

Features

A Walk-through automatic foot and hand washing station with a turnstile entry.
This system can be customized.

Features:

- Stainless steel Grade 304
- Welded body
- Adjustable leg height
- Compact design
- Heavy-duty robust brushes

Technical Specifications

- Dimensions: 1700 x 1100 x 1742 mm
- Power supply 480V, 60 Hz
- Control voltage 24V DC
- Power 0,6 kW
- Water supply 3/4"
- Wastewater outflow diam. 50mm

Customized options available

- Turnstile on left or right
- Rotate in one or two directions

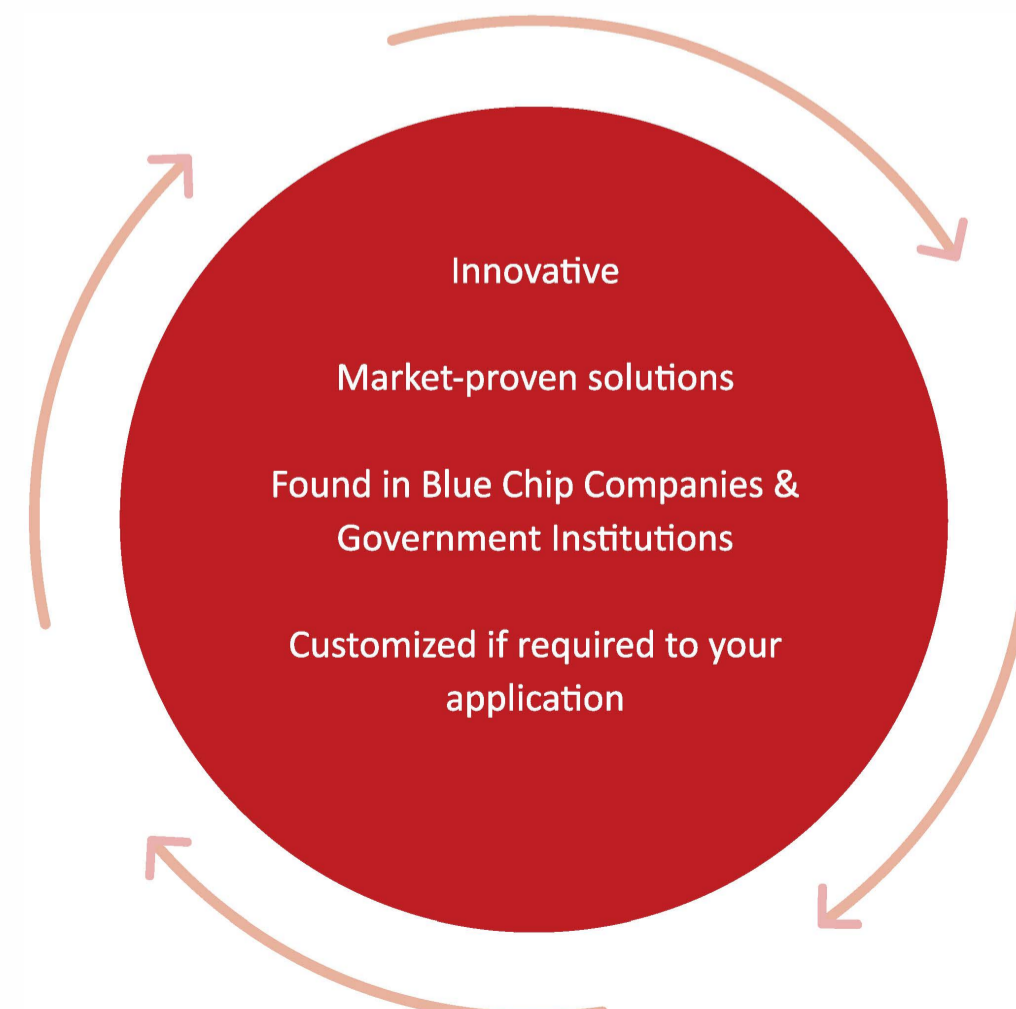

1 2 3 4 5 6 7 8

A
B
C
D
E
F

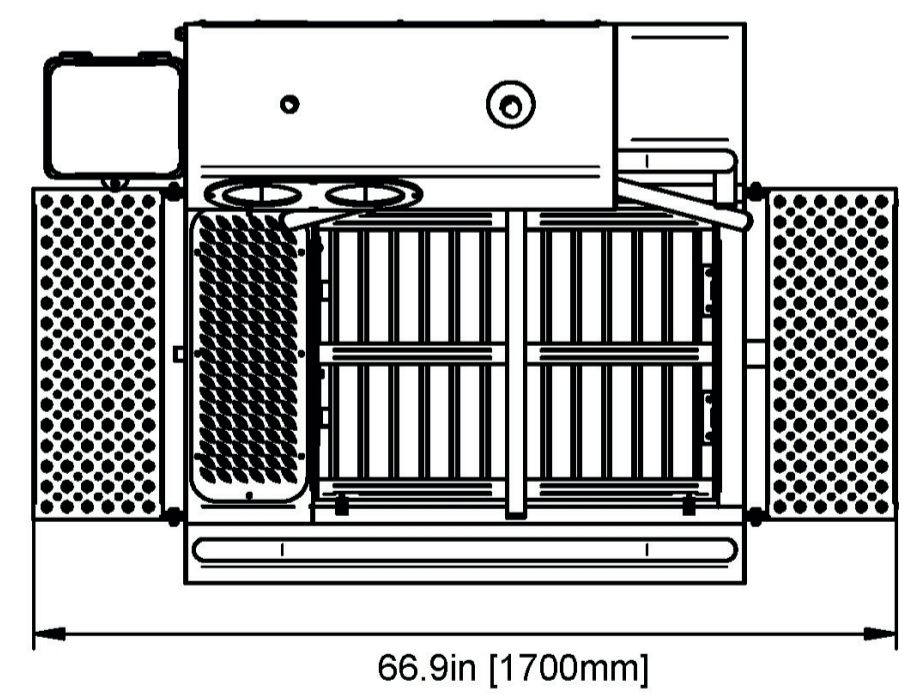
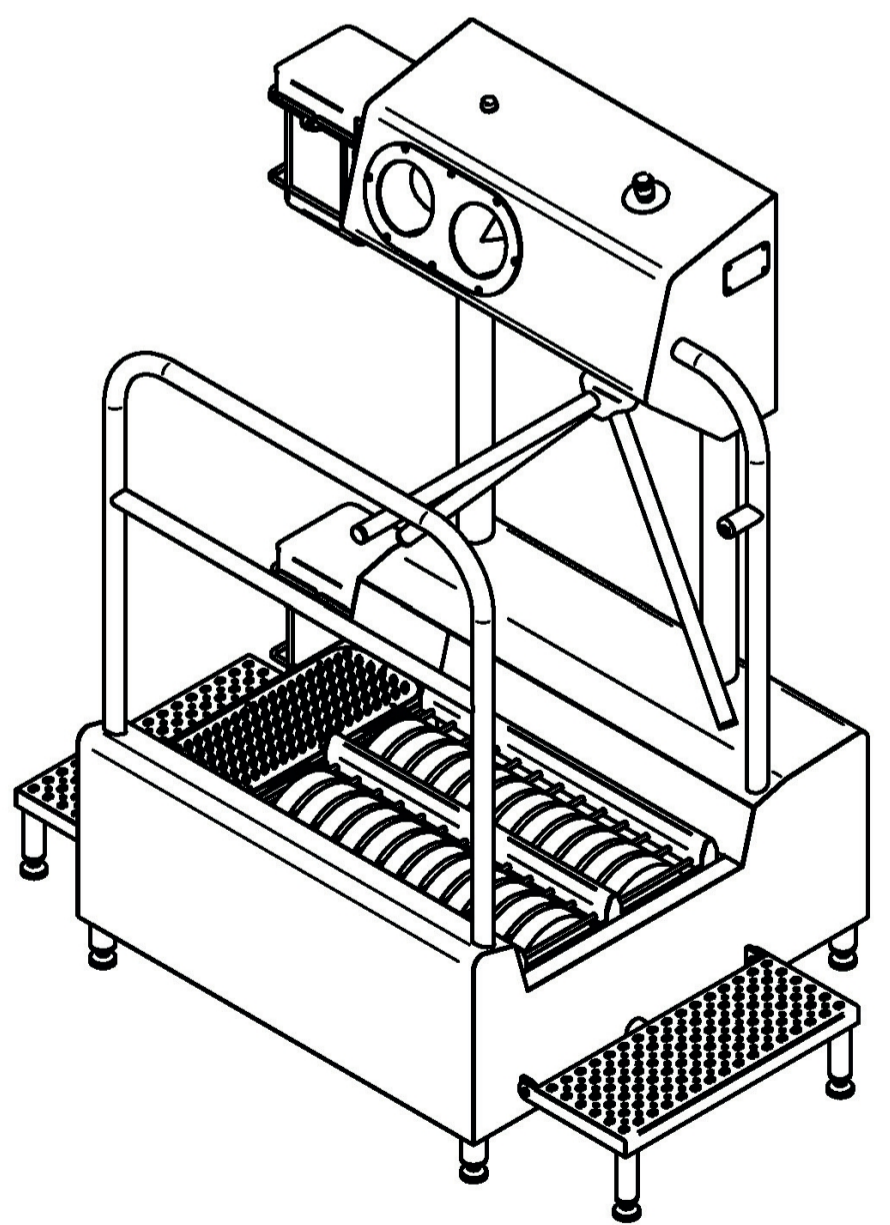
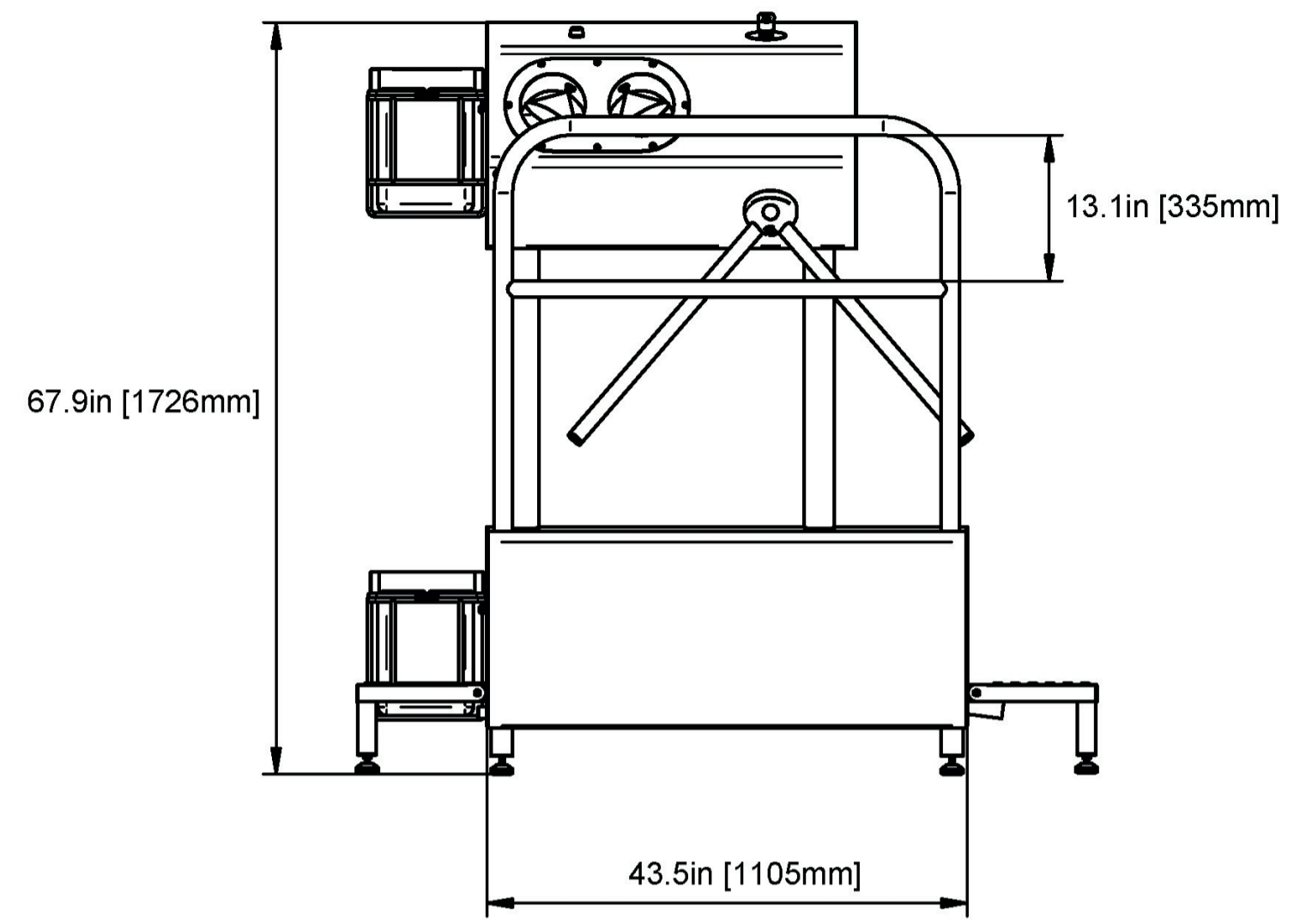
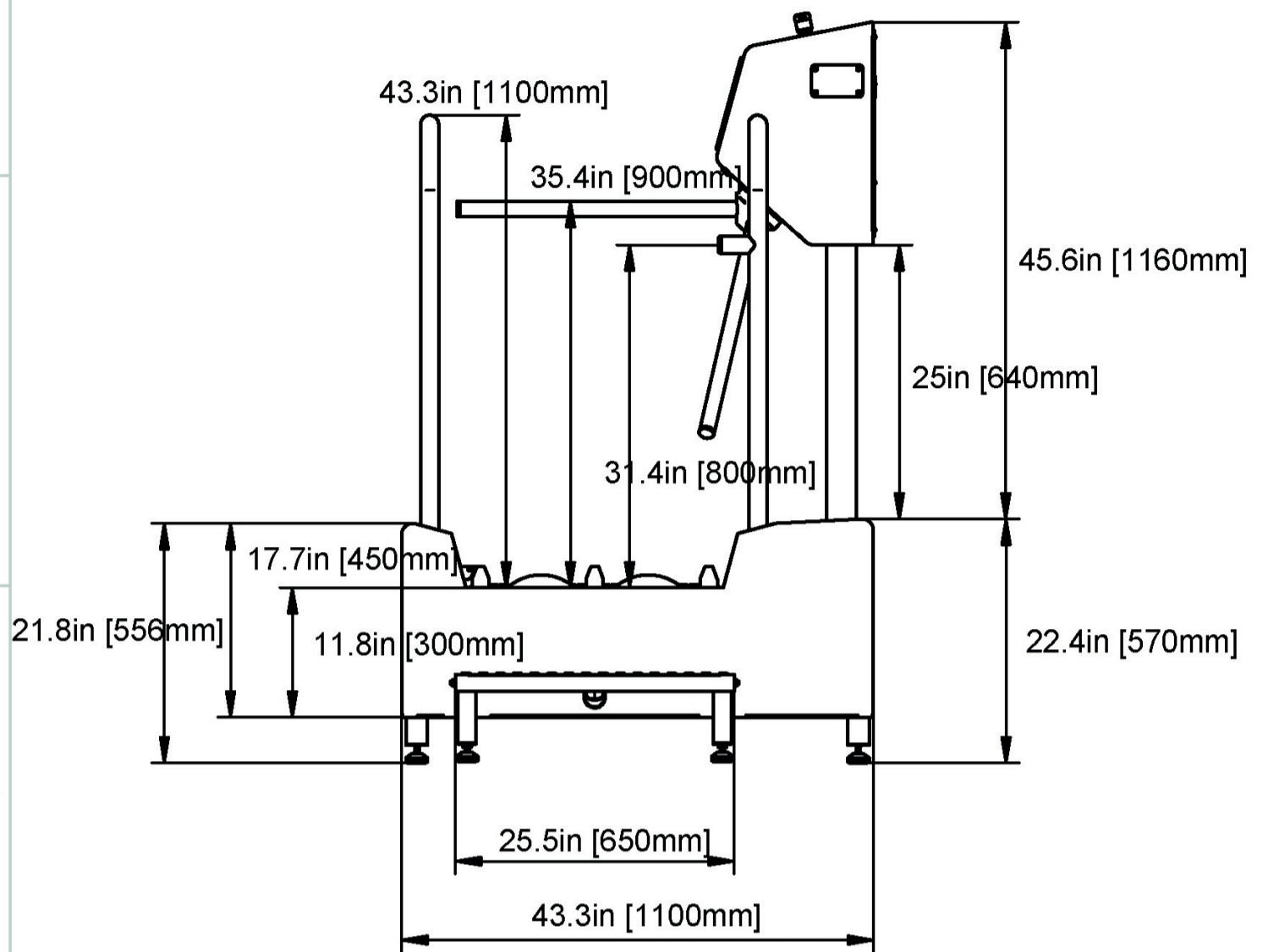

PROPRIETARY AND CONFIDENTIAL
The information contained in this drawing is the sole property of ISCA
Any reproduction, in part or as a whole, without the written permission of ISCA is prohibited.

Unless otherwise specified:
Dimensions are in inches [mm]
Surface finish:
Tolerances: imperial [metric(±15)]
Linear: x.xx 0.2 (.xxx 0.01)
Angular: xx' 010

product no:
**ISCA - Walkthrough
Automatic Foot and
Handwash Station**

1 2 3 4 5 6 7 8

Footwear storage

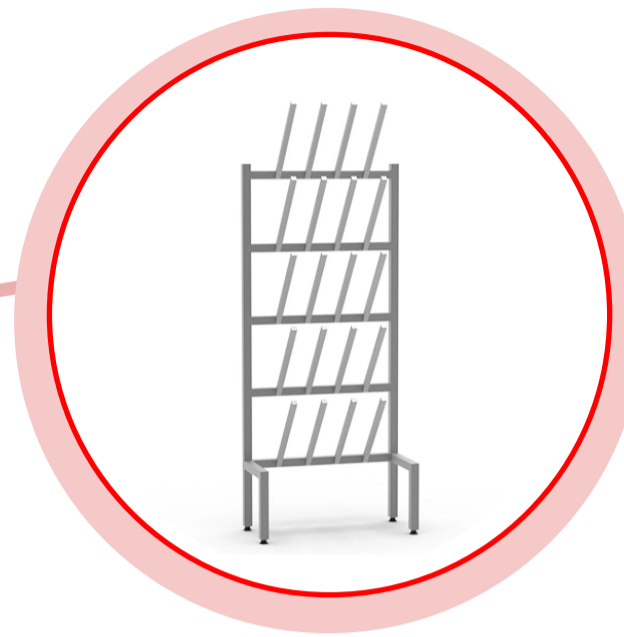

Workwear storage



**ISCA's
Hygiene
Equipment
Solutions**

Hygiene entrance stations



Manual bootwashers



Hand washing

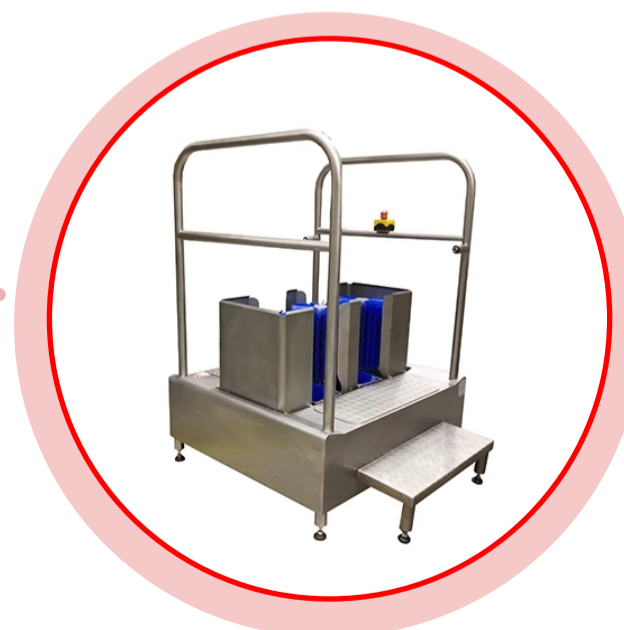

Automatic boot washers